



# Contractor Health, Safety & Environment Management System

## DOCUMENT REVISION HISTORY:

Rev #	Date of Revision	Originator	Reviewer	Approver
08	21/12/2018	C Senthil Kumaran	N Murali	Arul Shanmugasundram
09	30/01/2019	C Senthil Kumaran	N Murali	Arul Shanmugasundram
10	20/11/2020	K Ramprasad	Bhavani Shankar	Mahesh D Paranjpe



**Contractor Health, Safety &  
Environment Management System  
( CHSEMS )**

Doc. No.	CHSEMS / A3
Issue date	20/11/2020
Rev # & date	10 -20/11/2020

**Section-1:**

**Contractor Health, Safety & Environment (HSE) Competence Assessment**

Sl.no	Description	Page index
1	Pre-qualification of Bidders	07
2	Pre contract award process	07
3	Contract award process	08
4	Subcontractors	08
5	Post project Assessment	08

## Section - 2

### HSE Requirements & Procedures

SI	Description	Page index
1	Applicability and Enforcement	10
2	TATA Power Solar Systems Limited HSE Policy	11
3	Safety Code of Conduct	12
4	Tobacco Free Workplace Policy	13
5	Safety Organization & Responsibilities	14
	a. Contractor Site Management and Supervision	15
	b. Contractor Supervisors and General Staff	15
	c. Contractor Workforce	15
	d. Vendor/Contractor	15
6	General Safety Requirements	16
7	Job Safety Analysis (JSA)	18
8	Permit to Work (PTW)	19
9	Personal Protective Equipment (PPE)	20
10	Lock Out and Tag Out (LOTO)	21
11	Electrical Safety	24
12	Fire Safety	29
13	Excavation	32
14	Hand & Power Tools	33
15	Ladder Safety	36
16	Scaffold Safety	39
17	Confined Space Entry	42
18	Work at Height	43
19	Alcohol & Drug Usage	52
20	First Aid & Medical Service	53
21	Sanitation	55
22	Pre-Employment and Periodic Medical check up	58
23	Training	58
24	Workers Accommodation Requirement	59
25	Waste Management	60
26	Prevention of Pollution	62
27	Consequence Management Policy for Contractor	64
28	Tools, Tackles & Lifting Equipment's inspection	73



**Contractor Health, Safety &  
Environment Management System  
( CHSEMS )**

Doc. No.	CHSEMS / A3
Issue date	20/11/2020
Rev # & date	10 -20/11/2020

29	Construction Blasting method Statement	74
30	Incident Reporting and Investigation Protocol	77
31	Office Safety Procedures	81

## Definitions:

- The use of 'shall' indicates a mandatory requirement.
- The use of 'should' indicate a strong recommendation.
- The use of 'may' indicates is to be considered.
- 'HSE' means Health, Safety & Environment.
- 'LTI' means Lost Time Injury - An injury causing disablement extending beyond the day of shift on which the accident occurred.
- 'PPE' means Personal Protective Equipment
- 'LOTO' means Lock Out Tag Out
- 'PTW' means Permit To Work
- 'JSA' means Job Safety Analysis
- 'HIRA' means Hazard Identification & Risk Assessment
- 'GFCI' means Ground Fault Circuit Interrupter
- 'D.G' Set means Diesel Generator Set
- 'ELCB' means Earth-Leakage Circuit Breaker
- 'RCCB' means Residual Current Circuit Breaker
- 'SCBA' means Self Contained Breathing Apparatus
- ÚA means Unsafe Act
- ÚC means Unsafe Condition
- 'FAC' means First Aid Case
- 'MTC' means Medical Treatment Case



**Contractor Health, Safety &  
Environment Management System  
( CHSEMS )**

Doc. No.	CHSEMS / A3
Issue date	20/11/2020
Rev # & date	10 -20/11/2020

**SECTION – 1**

**Contractor Health, Safety & Environment  
(HSE) Competence Assessment**



**Contractor Health, Safety &  
Environment Management System  
( CHSEMS )**

Doc. No.	CHSEMS / A3
Issue date	20/11/2020
Rev # & date	10 -20/11/2020

Contractors, suppliers and others are key to our business performance, which includes our HSE performance. The minimum requirements for contractors and subcontractors working for TPS will be the same as the requirements imposed on all members of the TPS Project Team. These principles will apply to design, fabrication, and construction, installation commissioning and decommissioning activities. The capabilities and competencies of contractors to perform work on our behalf shall be assessed prior to awarding the contract.

The Project Team has defined the minimum HSE requirements for Contractors and these requirements are communicated to the contractors before starting the projects. The minimum HSE requirements should be reviewed and updated as necessary during the Project lifecycle.

Satisfactory Contractor safety performance will be accomplished by encouraging Contractors to invest and fully participate in the health and safety of their employees by developing, maintaining, and implementing their own safety programs. A Contractor's safety program (including health and environmental aspects) will be considered an important factor in determining award of contracts. Concern for employees, communities, and the local environment will be a guiding principle in all decisions.

We will use only qualified competent Contractors, i.e. Contractors that provide their services with people who are properly trained, well equipped, and efficiently supervised:

- Contractors must develop, maintain and implement their own HSE program
- Contractors must comply with applicable regulations, standards, policies and recognized safe work practices, as well as waste management and spill prevention practices
- Contractors must provide adequate and correct personal protective equipment and ensure their people are trained in its use and that it is used properly

Effective communication and understanding of responsibilities and standards are prerequisites for quality Contractor safety. TPS prime responsibility for Contractor safety is to ensure TPS safety requirements, standard safety practices, potential hazards, and site specific rules and procedures are communicated to, and understood by, the Contractors prior to commencement of work. This can be done through the bidding process, master services agreements, pre-job meetings, and/or site induction programs.

Contractors are responsible for the safety and health of their employees (including subcontractors) while in the service of TPS. This includes:

Training of their people to a competent level for the work they will be required to perform.



## Contractor Health, Safety & Environment Management System ( CHSEMS )

Doc. No.	CHSEMS / A3
Issue date	20/11/2020
Rev # & date	10 -20/11/2020

Ensuring that work procedures, practices, and equipment meet all provisions of TPS's rules, regulations, and standards.

Immediately reporting to TPS representative any incident or occurrence resulting in bodily harm to any of its employees, environmental release or impact, damage to the property of TPS or other parties arising from the Contractors' execution of the work.

Notify TPS representative on any near miss incident or occurrence that the most probable outcome may have resulted in a fatality, multiple serious injuries or illnesses or environmental impact.

The above requirements are intended to be captured for each specific contractor's scope of work in their HSE Documents

### 1. Pre-qualification of Bidders/ Suppliers

The Project & Procurement team shall pre-qualify and/or select all contractors using the **TATA Power Solar Systems Limited HSE Contractor Selection Questionnaire Annexure 1.**

Contractors will be required to use the same form for subcontractors who will work on the Contractor-manage site or TPS site. The completed forms will be reviewed by the Procurement, Project & HSE Team as part of the qualification/bid evaluation process.

Also considered in the qualification process:

- Post-project appraisals from previous jobs, if available.
- Safety record and HSE reputation.
- Information gathered during Contractor's site audits regarding safety programs and data submitted in the Questionnaire.

**Contractors who do not meet the minimum health, safety and environmental requirements and are deemed to have unsatisfactory safety performance shall not be considered for Next step.**

### 2. Pre Contract Award Process:

The Project/procurement Team will provide potential Contractors the **Section 2 of CHSEMS Plan** to ensure that they understand the safety principles, goals and objectives, and Adequately address them.



**Contractor Health, Safety &  
Environment Management System  
( CHSEMS )**

Doc. No.	CHSEMS / A3
Issue date	20/11/2020
Rev # & date	10 -20/11/2020

### 3. Contract Award:

The Project Team will review these HSE contract requirements with the contractors prior to execution of the contract to ensure mutual understanding.

The Contractor (or Sub-Contractor) shall develop a hazard assessment detailing specific hazards that their employees will be exposed to and/or introduced to during the project, and planned implemented mitigation activities. This will be reviewed by the Project Team to ensure that the Contractor has an adequate understanding of the hazards associated with their work.

**Contractor undertaking as per Annexure 2 shall be taken and copy of same should be shared with HSE team.**

### 4. Subcontractors:

Subcontractors shall be required to meet the same HSE requirements as Primary Contractors.

Primary Contractor shall be responsible for the HSE management of its subcontractors, including site orientation and training in HSE systems.

Prior to the selection of any subcontractors, Contractor shall undertake a thorough investigation of the subcontractor's HSE practices and identify any differences between Contractor's HSEMS and subcontractor's HSEMS. All identified areas shall be resolved prior to the subcontractor commencing Work.

All subcontracts shall allow for termination of the subcontract in the event of HSE violations by subcontractor personnel as per TPS HSE guidelines.

### 5. Post project Assessment:

When a contractor's work has been completed, the Project & HSE Team will evaluate major contractors' proactive HSE initiatives and performance using the **Annexure 3 post-project appraisal** form. This appraisal will be viewed as a shared learning and shall be documented and communicated with the Contractor and TPS as appropriate. Contractors should evaluate the performance of their Sub-Contractors.





**Contractor Health, Safety &  
Environment Management System  
( CHSEMS )**

Doc. No.	CHSEMS / A3
Issue date	20/11/2020
Rev # & date	10 -20/11/2020

## SECTION – 2

### HSE Requirements & Procedures

## 1. Applicability & Enforcement

Contractors and Contractor's Personnel are required to adhere to section 2 of CHSEMS at all times.

Contractor shall ensure that Contractor's Personnel provide goods and/or supply services in accordance with these procedures.

TATA Power Solar Systems Limited Corporate Health Safety & Environment Manual is integrated into these Instructions. Compliance with these Instructions means contractors are working to a level of safety equivalent to TATA Power Solar Systems Limited.

All persons who come into the work area, for any reason during construction, will be required to comply with the established safety regulations that govern the project.

If interpretation of an instruction is required, the Contractor should contact the Tata Power Solar Representative

**Failure of the Contractor or a Contractor's Personnel to comply with the requirements of these Instructions shall be deemed to be a material breach of the contract under which the Contractor has been hired to provide goods and/or services to TATA Power Solar Systems Limited and shall be grounds for termination of such contract.**

## 2. TATA POWER SOLAR Health, Safety and Environment Policy



### HEALTH , SAFETY AND ENVIRONMENT POLICY

We at Tata Power Solar reaffirm our belief that the health and safety of our stakeholders and environment protection is of the utmost importance and take precedence in all our business decisions. In pursuit of this belief and commitment, we strive to:

- Maintain and proactively improve our management systems to minimize health and safety hazards to our stakeholders and all others influenced by our activities.
- Ensure total compliance with all applicable occupational health, safety and environment regulations and other legal requirements.
- Integrate health, safety and environment procedures and best practices into every operational activity with assigned line-functional responsibilities at all levels for improving and sustaining health, safety and environment performance.
- Encourage employees in maintaining a safe and healthy work place through periodic reviews of operational procedures, safe methods of work and a safe working environment.
- Develop a culture of safety through active leadership and provide appropriate training at all levels to enable employees to fulfil their health, safety and environment obligations.
- Incorporate appropriate health, safety and environment criteria into business decisions for selection of plant and technology, performance appraisals of individuals and appointments in key positions.
- Conserve natural resources by improving efficiency and reducing wastages in our process and promoting the solar energy.
- Ensure availability at all times of appropriate resources to fully implement the health, safety and environment policy of the company.
- Actively communicate this policy to all stakeholders by suitable means and periodically review its relevance in a continuously changing business environment.



Ashish Khanna

CEO & Executive Director

Date: 10.09.2015 / Rev: 04

### 3.Safety Code of Conduct



**SAFETY CODE OF CONDUCT**

**Be PROACTIVE - BE Safe**

1. **PTW/PPEs:** I shall always obtain valid **"Permit to work"**, as also use the required PPEs as per zoning / job requirements.
2. **Report:** I shall always **Report** safety related incidents / observations and leverage it for learning and to avoid recurrence.
3. **Orderliness:** I shall maintain **Orderliness** at my workplace, to prevent trip, fall and accidents.
4. **Attention:** I shall always give personal **Attention** to ensure isolations, de-energisation, Lock Out and Tagout (LOTO) and other protective measures, to prevent unsafe operations.
5. **Conduct/Certification:** I shall demonstrate responsive **Conduct** and behavior to be safe personally and for others too. I shall never work or drive under influence of sedatives, drugs, alcohol or under fatigue situation nor allow others to do so, if in such a state.
6. **Traffic Rules:** I shall adhere to **Traffic rules** and shall not use mobile phone nor have any other distractions, while driving or as pillion-rider and keep driver under check.
7. **Interlock:** I shall never override any **Interlock** / safety critical trip without obtaining proper authorization and having full understanding of safety of such operations.
8. **Visibility:** I shall demonstrate felt leadership and be a role model, by **Visibly** pursuing ground-level visits and addressing gaps meticulously.
9. **Evaluate:** I shall **Evaluate** Hazard Identification and Risk Assessment (HIRA) and Job Safety Analysis (JSA) for effective risk control and avoidance of unsafe situations.

I commit to be **PROACTIVE** and **be SAFE**.

Employee Name : ..... Signature : .....

Employee No : .....

  
**Ashish Khanna**  
 CEO & Executive Director

Date: 08.12.2017/Rev 00

## 4.Tobacco Free Work Place Policy



TPS/HSE/2016-17/POL/006

### TOBACCO FREE WORK PLACE POLICY

A tobacco-free environment helps create a safe and healthy workplace. Smoking and secondhand smoke are known to cause serious lung diseases, heart disease and cancer. TATA Power Solar recognizes the hazards caused by tobacco use and exposure to secondhand tobacco smoke.

- Our policy to provide a tobacco-free environment for all employees and visitors was established to keep a safe and healthy workplace environment.
- This policy covers the smoking of any tobacco product and the use of oral tobacco products, "spit" tobacco and e-cigarettes, and it applies to both employees and non-employee visitors of TATA Power Solar
- No use of tobacco products including cigarettes and "Spit Tobacco" or e-cigarettes is permitted within the facilities or on the property of TATA POWER SOLAR at any time.

Date: 15.09.2016 / Rev : 00

  
Ashish Khanna  
CEO & Executive Director

## 5. Safety Organization & Responsibilities

### 5.1 Contractor Site Management and Supervision

Each Contractor will be responsible for fulfilling all statutory and safety requirements as per the laws of the land and not limited to Factory Act, Electricity Act, Electricity Rules and Regulations, Shop and Establishment Act etc.

Each Contractor shall provide at least one competent full time safety supervisor for workforce of less than 100 numbers. When workforce ranges from 100 to 1000, the contractor has to provide at least one qualified safety officer and safety supervisors (reporting to the safety officer) in the ratio 1:100. For every 1000 addition in workforce, the contractor has to add 1 safety officer. The TATA Power Solar Systems Limited Project Safety Manager will review and approve the appointment of all safety supervisors. Contractor/Subcontractor safety supervisors/officers will work with TATA Power Solar Systems Limited Safety Managers and align themselves with TATA Power Solar Systems Limited safety requirements.

Each Contractors'/Subcontractors' Site Manager is responsible, and will be held accountable, for the safety of their sub-contractors and workforce and for ensuring that all equipment, materials, tools and procedures remain in safety compliance at job site, including:

- 5.1.1 Holding officer/supervisors accountable for safety and actively promote safe work performance.
- 5.1.2 Participate in and co-operate with all safety program requirements to be implemented in order to meet TATA Power Solar Systems Limited safety objectives.
- 5.1.3 Ensure timely reporting of safety incidents, near misses, unsafe acts and unsafe conditions.
- 5.1.4 Identify the training needs of its employees and maintain all safety training documents.
- 5.1.5 Provide safety performance report at an agreed frequency.
- 5.1.6 Stopping of unsafe work (acts and/or conditions) immediately, until corrective action is taken.

## 5.2 Contractor Supervisors and General Staff

Contractors' site supervisors and general staff members in charge of job site functions such as field engineering, warehousing, purchasing, cost and scheduling, etc. are responsible for the safe performance of the work of those they supervise. They must set an example for their fellow employees by being familiar with applicable sections of the Site Safety program and ensuring that all site activities are performed with SAFETY as the primary objective.

Each site supervisor is responsible and will be held accountable for identifying, analyzing and eliminating or controlling all hazards through implementation of an aggressive, pro-active Health, Safety and Environmental Program from project inception through project completion. Each supervisor will proactively participate in the HSE program by observing, correcting unsafe acts, and recording these observations.

## 5.3 Contractor Workforce

Contractor workforce must make safety a part of their job by following safety rules and regulations and by using all safeguards and safety equipment. They must take an active part in the Site Safety program to ensure their own safety and injury-free employment as well as being alert to unsafe practices of their fellow employees.

Every member of the workforce is expected to report for work without influence of any Drug/Alcohol. All employees are expected to report any hazardous conditions practices and behaviors in their work areas and correct wherever possible.

Workforce is responsible for active participation in safety and health programs, suggestion systems, and trainings and in immediate reporting of all injuries, any unsafe practices, conditions or incidents to their supervisors.

## 5.4 Vendor/Contractor

Vendors/Contractors shall at all times comply with, and ensure that their workforce comply with all site safety rules and regulations. Specifically, with applicable provisions of the TATA Power Solar Systems Limited Site Safety Management Plan, and all statutory safety rules and regulations.



## 6. General Requirements:

### 6.1 HSE Induction:

Contractor shall ensure that their employees receive safety induction prior to starting work in the site. Each contractor shall maintain, and make available for inspection, records of such safety Induction and training. Record shall be maintained as per **annexure- 4 & annexure – 28**.

All personnel shall be issued a photo identity card duly signed by the authorized representative of the Contractor before they are engaged for any work at site. For work being carried out within the Company factory premises ID cards shall be as per the requirements of the factory.

### 6.2 Tool Box talk/Pep talk:

To brief the concerned personnel at the commencement of a job on its Potential Hazards so as to caution them on the associated risks and thus prepare them to take adequate precautions, make use of required PPE and Safety devices and protect themselves & others from the outcome of the anticipated risks

Following points are highlighted

- Specific hazards associated with the job.
- Risk control measures as identified in the Safe Work Method.
- Residual Risk involved.
- Case Study on previous similar accident / dangerous occurrence relevant to the job on which Pep Talk is given.
- Usage of PPE in the right manner.
- Motivation of workmen so as to develop safe work attitude.

Record shall be maintained as per **annexure- 5**

### 6.3 Personal Conduct:

- All Persons on Site shall comply at all times with all identified Tata Power Solar safety requirements, Contractor rules and Applicable Law.
- All Persons on Site shall be free from the use of alcohol or other intoxicants and shall abstain from the illegal use, possession, or distribution of controlled substances.
- All Persons on Site shall abstain from bringing onto the Site any firearm, weapon or illegal device of any nature.
- Horse play, pranks and games are prohibited



#### 6.4 Reporting unsafe acts/ Conditions/ Accident/Incident:

- All Persons are obligated to report any hazard, unsafe activity or condition to their supervisor.
- All Persons are obligated to identify any unsafe condition, activity, or qualification deficiency to the supervisor during Job Safety Analysis, the pre-job briefing, or at the work Site inspection.
- If a Person believes that a hazard exists that could jeopardize the safety of themselves or another worker, work must not proceed, and the situation must be immediately reported to the supervisor. The supervisor must ensure that the hazard is eliminated or controlled before work proceeds and must ensure that any Contractor Personnel required to perform that work are notified.
- All accidents, incidents, and workplace injuries/illnesses shall be reported in accordance with these Instructions.
- In the event of a Major Event or Catastrophic Event, the immediate location of such event shall be secured to prevent any disturbance of the scene until such time as an investigation has been complete. Project staff observation record shall be maintained as per **annexure- 29 & 30**, HSE staff observation record shall be maintained in **annexure 25** & Incident / accident shall be reported in **annexure - 27**.

#### 6.5 Jewellery and Clothing:

- Hair, clothing, jewelry, and all tools and equipment must be adequately contained to prevent entanglement with moving parts. Rings must not be worn near any source of entanglement.
- Jewelry, clothing, and tools and equipment with metal parts shall not be worn or used when there is a risk of contact with live electrical parts or circuits or when it can damage or render personal protective equipment ineffective.

#### 6.6 Barriers and Signage

- All Persons shall comply with Site safety signs, tags, or barriers.
- Only signs, tags, or barriers that are approved for use shall be installed

#### 6.7 Housekeeping and Storage

- Contractors shall ensure that work locations are maintained in an orderly and clean manner at all times.
- Equipment and materials shall only be stored in designated areas appropriate for that material

#### 6.8 Vehicle safety & Traffic Rules

- The contractor shall follow the speed limits of 20 KMPH /as per site guidelines
- Crash Helmet is mandatory for both driver & pillion.
- All vehicles entering site shall meet the requirement given in **annexure -6**
- Obey site traffic rules & Signs.
- Park the vehicles only in designated area.

## 7. Job safety Analysis (JSA)

The objectives of this procedure is to have a task based risk assessment process in place that identifies, evaluates and controls the risks associated with work activities, and as a result, prevents those involved in the task or those potentially affected by the task, from being harmed.

- Contractor shall ensure that Job Safety Analysis is made for each of the tasks carried out at TATA Power Solar Systems Limited.
- **Annexure 7** to this document is a template for a Job Safety Analysis.
- Contractor Personnel shall include in the Job Safety Analysis, the following at a minimum:
  - Selecting the job to be analyzed
  - Identifying potential hazards
  - An analysis of the impact of the potential impact and hazard such task could have on (a) other Contractor Personnel performing other tasks at the same time or nearby, (b) third parties, adjacent land owners, and members of the public,
  - Methods and procedures to eliminate or isolate the hazards, if any.
  - Barriers and procedures to reasonably control hazards that cannot be eliminated or isolated
  - Whether only a Competent Person may carry out the task or should supervise or perform a portion of the task.
- Contractor Personnel, who are the responsible supervisor for the particular task that is the subject of the Job Safety Analysis must review, approve and sign the Job Safety Analysis prior to any work commencing.
- A Job Safety Analysis must be signed by each Contractor Personnel that may be performing any of the functions of the task under such Job Safety Analysis.

- A Job Safety Analysis shall be reviewed by the Tata Power Representative

## 8. Permit to Work (PTW)

Permit to work (PTW) System is an essential element in controlling the workplace risks in an effective manner. Contractor personnel should take Permit to work from TATA Power Solar Systems Limited site representative before starting any at TATA Power Solar Systems Limited sites. ***Annexure 8A & 8B of this document is the template for PTW.***

Following are the three types of PTW followed at TATA Power Solar Systems Limited:

1. High Risk work Permit
2. Medium Risk work Permit
3. Low Risk work Permit

**8.1 HIGH RISK WORK PERMIT:** This permit is for high risky jobs which includes

- Confined Space Entry
- Working at Height where no permanent Platforms
- Working at Fragile roofs
- Excavation work
- Demolition work
- Chemical Handling
- Working in remote area
- Electrical work involving High voltage
- Heavy material loading/unloading
- Hot Work (Welding/cutting work)
- Any other hazardous nature of work where there is a chance of fire, explosion, Electrocution, Risk to human Life etc.

**8.2 MEDIUM AND LOW RISK WORK PERMIT:** This permit is for Medium & Low risky jobs which includes

- Non-routine Breakdown maintenance, which doesn't have JSA/Procedure.
- Painting/civil work in less than 2 meter height
- Non-routine Cleaning work
- Machine/equipment/Scrap shifting
- New activity at unauthorized location
- Electrical work which does not need LOTO
- Any other less risky job in nature which is non-routine

### 8.3 Permit to Work (PTW) Issue Process

- Discuss the job going to be executed with the executing in charge.
- Prepare a method statement
- Prepare a JSA.
- Take the work permit.
- Ensure the Work permit is completely filled.
- Ensure the JSA and PTW is approved by the authorized persons.
- Ensure the control measures are established (PPE's, Supervision, barrication, etc.,)
- Conduct the Toolbox meeting
- Monitoring the compliance during the job execution
- After completing the job, the work permit has to be formally closed and to be filed as a record in their respective department
- The validity of Work Permit shall be 8 hrs only and may be extended further after obtaining consent from TATA Power HSE in-charge or its representative.

## 9. Personal Protective Equipment(PPE):

This section provides the minimum requirements for the use of PPEs. PPEs are designed to protect individuals from possible harm caused by health and safety hazards. The Contractor is responsible for assessing the needs for PPE, selecting appropriate PPE for the purpose of protection of individuals from the particular risks, informing Contractor's Personnel of the specific requirements for PPE, and ensuring that the use of PPE by all Contractor Personnel.

The Contractor is responsible for assessing the needs for PPE, selecting appropriate PPE for the purpose of protection of individuals from the particular risks, informing Contractor's Personnel of the specific requirements for PPE, and ensuring that the use of PPE by all Contractor Personnel.

### 9.1 Minimum PPE Requirements:

*Annexure 9 of this document gives the minimum PPEs to be used & applicable standards.*

### 9.2 Inspection and Testing:

The Contractor shall, or shall ensure that Contractor’s personnel shall, inspect all PPEs prior to each use. Such inspections shall include identifying (a) obvious signs of wear, (b) tears, holes, cracks, or leaks, (c) the proper function of closures, if any, and (d) the status of seams. Any PPE found to have excessive wear, tears, punctures, or any defect of any nature shall be discarded and replaced with new PPE. All inspections and testing of PPE is to be logged and available to the TATA Power Solar Systems Limited representative for review and record keeping.

## 10. Lock out and Tag Out (LOTO):

The Contractor shall, or shall ensure that Contractor’s personnel shall, meet the requirements set out in this Section.

LOTO shall be required whenever start up, testing adjustment, commissioning, service, maintenance, or modification is being performed on equipment or apparatus in which the unexpected energization or start-up of the equipment, or release of stored energy, could cause injury to people or damage to the equipment.

Hazardous energy sources must be isolated or de-energized prior to the commencement of any work on such source or near such source as set out in these Instructions. Examples of such energy sources include primary and secondary sources:

- Electrical
- Mechanical (rotational and gravity)
- Chemical
- Pressure or Vacuum (Hydraulic or pneumatic)
- Steam
- Stored
- Thermal
- Ionizing and non-ionizing radiation sources.
- Hydraulic fluids
- Pressurized Water Systems
- Compressed Gases/Air

### 10.1 Application:

- Prior to commencing any work on a machine or piece of equipment that has an energy source during which unexpected energizing or movement could occur and cause injury, the machine or equipment shall be isolated or de-energized by locking out all

energy using isolating devices and indicating the status of such machine or equipment through the use of obvious Lock-outs and Tag-outs

- While most equipment is capable of accepting locks, if a piece of equipment or machine is not capable of implementing a lock, TAGS MUST BE USED.
- The Contractors shall cooperate and coordinate all LOTO with Tata Power Solar Representative.

### 10.2 Notification of Employees

- All affected Contractor Personnel and TATA Power Solar Systems Limited personnel shall be notified by the Contractor Personnel of the application or removal of LOTO devices.
- This notification shall be given before LOTO devices are applied and after they are removed.

### 10.3 Application of Control

- Before starting work which requires a LOTO device, Contractor's Personnel shall obtain PTW (see Annexure 8a)
- Contractor's Personnel shall make certain that relevant machines or pieces of equipment have been isolated or de-energized, and all electrical switches, breakers, valves (water, steam, air), and mechanical linkages have been safely disconnected.
- All energy-isolating devices shall be physically located. Some systems may have more than one source or type of energy.
- If equipment is capable of being Locked-out, Contractor's Personnel shall apply a lockout device. A lock clearly and obviously identified as a safety lock shall be used as the lockout device.
- Machines or pieces of equipment that cannot be Locked-out shall be Tagged-out. The machine or equipment shall be affixed with tag, attached to the energy isolating device (switch or valve) together with a secondary protection in place to minimize the hazard to the greatest extent possible. Examples include:
  - Removal of an isolating circuit element
  - Blocking of a controlling switch or;
  - Opening of an extra disconnecting device.
  - Personnel posted at location during entire process
- All potentially hazardous stored or residual energy shall be relieved or otherwise rendered safe in the same manner.
- When a Tag-out device is used on an energy-isolating device, it shall be attached at the same location as the energy-isolating device. If this is not possible, the tag shall be

located as close as possible to the lockout device. The tag must be affixed with a non-reusable nylon cable tie.

- Work on cord and plug-connected electrical machine or equipment may be controlled by unplugging the equipment. If the plug is under the exclusive control and sight of the Contractor Personnel performing the service, no LOTO is required.
- More than one LOTO shall be attached to the same energy control when more than one Contractor Personnel is working on the same machine or equipment.

#### **10.4 Verification of Isolation**

- Before starting to work on machine or equipment that has been Locked-out or Tagged-out, Contractor's Personnel shall verify that the machine or equipment has been isolated and de-energized. Care must be taken to employ only the proper test equipment to verify that the system is safe. Only persons trained to use test equipment shall conduct the verification.
- The possibility of re-accumulation of stored energy to a hazardous level must be addressed by continuous verification of isolation until there is no accumulation of energy.
- After the energy source is positively tested to verify that all energy sources are isolated and after ensuring that no Contractor Personnel are exposed, the normal operating control shall be exercised to make certain that the machine or equipment will not operate.
- Appropriate equipment must be used to ensure that machinery and equipment has reached zero energy state prior to conducting work on the machinery and equipment.

#### **10.5 Removal of LOTO**

- A LOTO shall not be removed by anyone except the Contractor Personnel that attached it. The only exception to this is when the Contractor Personnel who attached the LOTO is not available. If the Contractor Personnel who attached the LOTO is not available, then the removal may only be conducted in accordance with the procedure "Removal of Lockout/Tag out by Personnel Other Than the One Who Applied It" set out in these Instructions.
- With respect to the removal of LOTO, Contractor Personnel at a minimum shall implement a procedure, material similar to Attachment 10C.

#### **10.6 Removal of Lockout / Tag out by Personnel Other Than the One Who Applied It**

- This procedure is only to be used if a LOTO device is to be removed by someone other than the individual that originally applied the LOTO device.
- A committee of three persons, which shall include 2 Contractor Personnel, one of whom must be a supervisor, together with the TATA Power Solar Systems Limited representative



shall determine if it is safe to remove a LOTO device. Such determination to remove shall only be permitted if all three agree that is safe to remove such device.

- The procedure for removal of the LOTO device shall include:
  - Verifying that the individual that originally applied the LOTO device is not present at the Site or reasonably available to attend at the Site.
  - Properly remove the LOTO device in accordance with these Instructions.
  - The removal shall be documented in writing, which shall include the names of the Device Removal Committee, the date, the time, the name of the individual that originally applied the LOTO device, and the procedures implemented to verify the absence of such individual.
  - Ensuring that the individual that originally applied the LOTO device has been informed that his or her LOTO device was removed before he or she resumes work.
  - Notifying such individual’s supervisor that the LOTO device was removed.
  - Place a written notice at the individual that originally applied the LOTO device’s workstation.

## 11. Electrical Safety:

The objective of this procedure is to specify minimum mandatory requirements and advisory guidance for identifying and controlling hazards to ensure ‘Zero Harm’ with regard to operation maintenance, testing and using of electrical equipment/appliances. The Contractor shall comply with the requirements set out in this procedure.

### 11.1 General Requirements:

The Contractor shall, or shall ensure that Contractor’s Personnel shall, comply with the following requirements:

- Only a Licensed Electrician shall work on live electrical equipment, and any other associated work that does not require a Licensed Electrician shall only be worked on by a Competent Person.
- All electrical equipment, circuits, or other energy containing shall be deemed to be “live” unless determined otherwise by a Licensed Electrician in accordance with these Instructions.
- All non-current carrying metal parts of equipment or devices, such as transformer cases and circuit breaker housings, shall be deemed to be “live” at the highest voltage to which they are exposed, unless determined otherwise by a Licensed Electrician in accordance with these Instructions, including verifying proper grounding.
- Except as is expressly set out in these Instructions, these Instructions do not apply to Low Voltage Equipment.



- Electrical equipment, circuits, or other energy containing items may only be de-energized by a Licensed Electrician.
- LOTO devices and procedures shall be utilized and implemented at all times when Contractor Personnel are working on electrical equipment, circuits, or other energy containing items.
- LOTO procedures shall be implemented in accordance with these Instructions.
- LOTO devices or installations shall only be removed in accordance with the LOTO procedures set out in these Instructions.
- Equipment, circuits, or other energy containing items which are subject to a LOTO shall not be operated at any time
- Contractor Personnel shall avoid contact with any structure or vehicle that is in direct contact with any exposed energized electrical equipment, circuits, or other energy containing items.
- The standard color scheme for phase identification must be verified for all electrical connections, regardless of the voltage amount (e.g. black, red, white).
- All Contractor Personnel who will be performing work on electrical equipment, circuits, or other energy containing items or who have the potential to come into contact with electrical equipment, circuits, or other energy containing items shall wear appropriate electrical safety PPE.
- All Contractor Personnel shall remove all personal items that may conduct electricity prior to attending at the project Site each day, including metal rings, jewelry and belt buckles.
- Electrical equipment may not be used unless the manufacturer's name, trademark, or other descriptive marking by which the organization responsible for the product may be identified is clearly perceptible on the equipment.
- Other markings shall be provided on all electrical equipment clearly showing, at a minimum, voltage, current, wattage, or other material ratings. Such markings shall be of sufficient durability to withstand the environment involved.
- Work shall not be performed on equipment until Contractor Personnel understand the electrical equipment operations, are fully trained to complete the task required, have confirmed all adequate safety precautions are in place, and have completed a safety risk assessment

**11.2 Hand Tools, Portable Equipment and Lighting**

- The Contractor shall, or shall ensure that Contractor's Personnel shall, comply with the following requirements:
- Only power tools and portable equipment that is certified by a Recognized Certifier shall be used.

- Power tools and portable equipment shall only be used, inspected, and repaired by a Competent Person and only in accordance with manufacturers' specifications.
- Power tools and temporary lighting, including double insulated tools and extension cords, shall at all times be protected by a ground fault circuit interrupter (GFCI), which GFCI must be installed as close to the supply source as possible, unless an exception has been approved by a Licensed Electrician.
- GFCI breakers must be installed on all "temporary" power panels and only a Licensed Electrician shall perform such installations.
- Portable GFCIs shall be available for protection when the power supply is from permanent receptacles.
- Portable GFCIs shall only be installed within three (3) feet of the source.
- A regular check of GFCIs shall be performed by a Licensed Electrician to ascertain that they are working properly.
- If a GFCI faults, the cause of such fault shall be investigated and determined by a Licensed Electrician prior to the resetting of the GFCI.
- Plugs and cords must be compatible with grounded equipment, for example 3-prong receptacles and extension cords. Do not alter or remove the grounding prong on the plug. Double insulated tools need not be grounded. Do not use adapters, which interrupt the continuity of equipment grounding.
- Power tools shall be double insulated or equipped with a grounding system and a polarized cord connector.
- All tools used on or near live exposed electrical equipment must be double insulated and approved for use by a Licensed Electrician.
- Only meters and test equipment that have been certified by a Recognized Certifier shall be used.
- Temporary lights must have guards to prevent accidental contact with the bulb. Lights shall not be suspended by their electric cords.
- Hand lamps must be of molded composition or other type approved for the purpose. Do not use brass-shell or paper-lined lamp-holders. Hand lamps must have a handle, a substantial guard over the bulb, and be attached to the lamp holder or the handle.

Record shall be maintained as per annexure- 22 a & 22 b.

**11.3 Temporary Cables and Extension Cords:**

The Contractor shall, or shall ensure that Contractor's Personnel shall, comply with the following requirements:

- Only cable and extension cords that are designed for the particular use to which is being put shall be used.

- Only three-wire extra-heavy duty extension cords (14 gauge or larger) may be used with portable electric tools and appliances.
- Only 16 gauge (or larger) extension cords will be used with portable test equipment that requires very low amperage to operate
- Extension cords shall be inspected prior to each use. Damaged extension cords shall immediately be taken out of service and clearly tagged as out of service.
- Only temporary power supplies that have been certified by a Recognized Certifier shall be used, including extension cords manufactured by a Licensed Electrician.
- Electrical power cables used for temporary service shall be clearly identified, not be exposed to crush hazards and will be hung overhead and securely supported whenever possible. Wire nails, or other conductive material, will not be used to hang or attach cords sets or welding leads.
- Electrical power cables laid on the floor or ground shall be inspected regularly by a Licensed Electrician, secured and protected from damage due to travel hazards. Such cords shall not be secured with staples or any other device that could cause damage to the insulation.
- Do not plug or unplug electrical equipment and extension cords with wet hands.
- Do not use flexible electric cords to raise or lower tools or equipment.
- Protect extension cords from accidental damage that may be caused by traffic, sharp corners, or projections and pinching.
- Keep working spaces, walkways, and similar locations clear of extension cords so as not to create a hazard to Contractor Personnel.
- Do not use adapters that interrupt the continuity of equipment grounding.
- Properly secure locking type connectors.

#### **11.4 Abandoning Cable:**

Contractor shall, or shall ensure that Contractor's Personnel shall, comply with the following requirements:

- Contractor Personnel shall immediately remove all abandoned cable completely as soon as is practicable.
- Abandoned cable shall be disconnected at both ends, shrink wrap cables shall be applied to both ends.
- The end closest to the supply source shall be grounded to eliminate the risk of induced current.

- Contractor Personnel shall immediately tape the ends of abandoned cables with a distinctive colored and highly visible tape, and shall label the tape with the Contractor Personnel's name, the date, and any other relevant information (e.g. old cable #, source/destination).

### **11.5 Operations Adjacent to Overhead Lines:**

- Overhead transmission and distribution lines shall be carried on towers and poles that provide safe clearances over roadways and structures.
- Clearances shall be adequate for the movement of vehicles and for the operation of construction equipment.
- Work activity adjacent to overhead lines shall not be initiated until a survey has been made to ascertain the safe clearance from energized lines.
- Any overhead wire shall be considered energized unless the person owning such line or operating officials of the electrical utility supplying the line confirms in writing that it is not energized and it has been visibly grounded.
- Operations adjacent to overhead lines are prohibited unless at least one of the following conditions is satisfied:
  - Power has been shut off and positive means taken to prevent the lines from being energized,
  - equipment, or any part, does not have the capability of coming within the minimum clearance from energized overhead lines – which is at least 3 m (10 ft.) for voltages of 50 kV or less and increased 0.4 inches for each 1 kV above 50kV, or the equipment has been positioned and blocked to assure no part, including cables, can come within the minimum.
- Work activity that could affect or be affected by overhead lines shall not be initiated until coordinated with the appropriate utility officials.

## 12. Fire Safety

Objective of this procedure is to specify the minimum mandatory requirements and advisory guidelines to ensure prevention of fire related incidents and managing / controlling their impacts if they do occur.

### 12. 1 General Requirements

The Contractor shall, or shall ensure that Contractor's Personnel shall, adhere to the requirements of this fire protection program.

- Temporary fire protection measures including fire extinguishers, temporary hose lines, and temporary standpipes are required at all times during the conduct of work and services at the Site.
- Fire extinguishers shall be:
  - Conspicuously located
  - Certified annually and inspected monthly
  - Protected from freezing
  - Placed within the immediate area of any welding or metal cutting operation or flammable liquid storage area.
  - Placed within five feet of any gasoline operated equipment at all times while such equipment is in use.
- All firefighting equipment shall be maintained in accordance with the manufacturers' recommendations.
- Defective firefighting equipment and fire extinguishers that have been used in any way shall be immediately replaced.
- Each temporary building, trailer, vehicle (shops, field offices, storage boxes, etc.) are required to have its own appropriately sized and located class ABC fire extinguisher
- Access to fire hydrants and extinguishers shall be maintained at all times
- Blocking routes of ingress and egress access routes is prohibited.
- All Contractor Personnel shall be trained in the basics of portable fire extinguisher use.

### 12.2 Fire Prevention

- Temporary buildings located within another building or structure shall be constructed of non-combustible material or have a fire resistance rating of one (1) hour. Plastic tarps or covers (polyethylene) used for any purpose inside an occupied building or where welding, cutting or open flame is present shall be made of fire retardant material.
- Combustible refuse from construction operations will not be burned or dumped anywhere on the construction Site. Such refuse will be removed at frequent intervals,

as needed. Storage of large quantities of construction debris will be placed in metal dumpsters.

- Compressed gases shall be stored in accordance with the following:
  - Valves, regulators, and hoses removed with valve caps securely on
  - Secured upright at all times, including when transported in vehicles.
  - Fuel and oxygen cylinders separated by a minimum of 20 feet
  - Empty cylinders stored separate from full cylinders.
- Only approved high flash point solvents are to be used for cleaning purposes.
- Oily rags and waste are to be stored separately in metal containers fitted with self-closing lids. Trash and refuse must be placed in trash containers provided for this purpose.

### 12.3 Hot Work

- Prior to performing any Hot Work, Contractor Personnel shall obtain PTW from TATA Power Solar Systems Limited
- A Hot Work permit shall only be valid for the date and shift that is stated on the permit.
- All precautionary measures listed on the Hot Work permit must be followed.
- Contractor Personnel performing Hot Work shall be trained in such work by a Recognized Trainer, and such training shall include:
  - A review of the work to be performed
  - Precautions to be taken
  - Emergency procedure in case of fire
  - How to use the fire extinguisher correctly

### 12.4 Maintenance

- Portable firefighting equipment shall be maintained as per the manufacturer's recommendations, shall be inspected on a regularly occurring basis and kept in good working order at all times.
- All portable fire extinguishers shall be visually inspected at least monthly.
- Visual inspection shall include verifying that:
  - The shell has not deteriorated due to corrosion or been damaged by other means;
  - The pressure gauge measures a fully charged/pressurized state;
  - The discharging mechanism is undamaged and in good working order; and
  - All hoses, connections, and other appurtenances are present and undamaged.
  - Logs of all inspections shall be maintained by the Contractor.

Record shall be maintained as per **annexure- 24**

### 12.5 Ignition Hazard

- Internal combustion engine powered equipment shall be so isolated that the exhausts are well away from combustible materials. When the exhausts are piped to outside the

building under construction, a clearance of at least 6 inches shall be maintained between such piping and combustible material.

- Smoking shall be prohibited at or in the vicinity of operations which constitute a fire hazard. Absence of "No Smoking" signs shall not excuse smoking in dangerous places.
- Portable battery powered lighting equipment, used in connection with the storage, handling, or use of flammable gases or liquids shall be of the type approved for the specific hazardous locations.

### 12.6 Open Yard Storage

- The entire storage Site shall be kept free from accumulation of unnecessary combustible materials. Weeds and grass shall be kept down and a regular procedure provided for the periodic cleanup of the entire area.
- When there is a danger of an underground fire, that land shall not be used for combustible or flammable storage.
- Method of piling shall be solid wherever possible and in orderly and regular piles.
- All stored materials such as wooden planks and plywood must be treated with fire retardant solution.
- Authorized lay down areas shall contain only the necessary materials for specific work activities and must be promptly removed once the work is complete.

### 12.7 Indoor Storage

- Storage shall not obstruct, or adversely affect, means of exit.
- All materials shall be stored, handled, and piled with due regard to their characteristics
- Incompatible material, which may create a fire hazard, shall be segregated by a fire resistant barrier.
- Use approved metal safety cans to store flammable and combustible liquids indoors in minimal quantities (for one day's use only).
- Materials shall be piled to minimize the spread of fire internally and to permit convenient access for firefighting. Stable piling shall be maintained at all times. Aisle space shall be maintained to safely accommodate the widest vehicle that may be used within the building for firefighting purposes.
- Clearance shall be maintained around lights and heating units to prevent ignition of combustible materials.
- Gas torches must never be placed in boxes or cupboards while connected to a gas supply.



## 13. Excavation

This procedure is developed to establish mandatory requirements for practices to protect personnel, property and equipment from hazards associated with excavation activities.

### 13.1 Job Pre-Planning

- Pre-planning is an essential part of an excavation operation.
- The Contractor or Contractor’s Representative shall appoint a Competent Person to be directly responsible for all excavation activities, including supervising all persons engaged in the activities involving Breaking the Surface and shall supervise all breaking of the surface activities
- The Contractor is responsible for locating all existing below surface buildings, utilities, structures, pipes, conduits and works including gas pipes (both liquid and gaseous pipes), electrical conduits, drainage systems (including weeping tiles) and water transportation piping. In order to identify all existing underground services, the Contractor shall contact all utility owners that could reasonably be expected to have such below the surface structures at or in the vicinity of the Site.
- The Competent Person shall develop a Job Safety Analysis for the excavation activities.
- Excavation operations may only be commenced if they have been previously approved by the Contractors professional engineer.
- During excavation, the following requirements will be followed:
  - All trenches and excavations will be barricaded and signage posted at the work area.
  - Fall protection shall be provided for excavations six feet or more in depth.
  - Trenches or excavations will be sloped or benched in accordance with Applicable Law, and as determined by the designated Competent Person.
  - Supporting systems (i.e. shoring, piling, trench boxes, etc.) will be utilized for all trenches and excavations where sloping or benching could not be performed.
  - Spoil piles and all other material will be placed a minimum of two feet from the edges of all trenches or excavations.
  - When underground utilities are suspected, they will be located first by hand digging.
  - Adequate access must be maintained at all times during trenching or excavating activities. Access points will be placed such that no worker travels more than 25 feet in any direction.



- The Competent Person will inspect excavations and trenches at the beginning of each day before work begins and when conditions change.
- Excavations in Type C soil will not be benched.
- Excavations and trenches four feet or greater in depth will be evaluated for atmospheric hazards to determine whether permit required confined space requirements apply.

## 14. Hand & Power Tools

Hand and portable power tools are used extensively in the construction of solar facilities. Injuries involving, hand and portable power tools are common injury hazards at an industrial construction Site, and injuries can include minor cuts, lacerations, broken bones, bruises, amputation, and loss of sight. In general, the hazards from portable power tools are similar to those from the corresponding stationary power tools. In addition, there are risks from handling the portable tools when they are energized. For power tools, the saw blade or other work surface is usually in motion, presenting the potential for serious injury. The use of power tools also increases the risk of electrical shock, fires and explosions involving flammable gases and vapors.

### 14.1 Types of Hand and Portable Power Tools

**Hand tools can be grouped into the following general categories:**

- striking tools (hammers, mallets, sledges);
- turning tools (wrenches);
- metal-cutting tools (shears, snips, bolt cutters, wire cutters, hacksaws, metal chisels, and files);
- wood-cutting tools (hand saws, drills, planes, axes, hatchets, wedges, mauls, and wood chisels);
- material handling tools (crowbars, hooks);
- gardening tools (shovels, rakes, hoes, and post-hole diggers);
- screwdrivers
- pliers
- knives and miscellaneous cutting tools (scissors, scrapers, bits, and awls)

**Power tools are usually grouped according to their power source as follows:**

- electric
- pneumatic
- gasoline
- hydraulic
- powder-actuated

## 14.2 General Requirements

**When using all hand and power tools, the Contractor shall, and shall ensure that the Contractor's Personnel shall:**

- Ensure that all hand and power tools are kept in good condition with regular maintenance
- Operated according to manufacturer's instructions and guidelines
- PPE appropriate for the hand or power tool will be worn
- Use tools only for the purpose for which they are designed and intended.
- Select tools that fit the work piece securely (e.g., screwdrivers that fit snugly in the screw slot, wrenches that fit snugly around the nut, etc.).
- Use non-sparking tools if a fire or explosion hazard exists.
- Have available the manufacturer's rating and instruction manual for each power tool.
- Electric tools must have a three-wire cord unless they are double insulated

**When using hand and power tools, the Contractor shall not:**

- Use any tool unless the individual is familiar with its safe operation.
- Use any tools unless the individual's footing and balance are stable
- Use a damaged or faulty tool (i.e. mushroomed heads, cracked handles, guards removed etc.)
- Alter the basic configuration of the tool or use a tool which has been altered, except in accordance with the manufacturers' specifications and instruction manual.
- Use any handle extensions or adapters unless they are specifically designed for the tool and for the purpose for which the tool is being used in the particular activity.
- Expose tools to excessive heat.
- Use hammers, wrenches, screwdrivers, or other tools in place of a pry bar or chisel.
- Engage in any kind of horseplay with tools.
- Use grinding disks that are not matched to the grinder rpm in accordance with the manufacturer's specifications and instructions.
- Use adaptors that are not approved in accordance with the manufacturer's specifications and instructions
- Use cutting disks for grinding.
- Operate any power tool without the implementation and use of any guards or protective safety devices included with the power tool.
- Permit power tools to be carried by their electric cord, airline, or hydraulic hose.
- Permit the carriage by hand of hand or power tools while simultaneously ascending or descending ladders or very steep stairs.
- Permit individuals to throw any hand or power tools at or toward another person.

- Permit the carrying of hand or power tool in a manner which obstructs the vision of the individual carrying such hand or power tool in any manner.
- Permit toolboxes to be used as something to stand on, as benches, as saw horses, for storing lunches, or for any other purpose which is not the storage of tools.

### 14.3 Safety Training and Inspection

The Contractor shall ensure that all of Contractor's Personnel receive training with respect to the use of all hand and power tools. Training should include:

- how to select the proper tool for the job?
- how to use these tools properly?
- procedure for inspection of tools
- procedures for storage of tools
- procedures for repair of faulty tools
- the importance of planning jobs ahead so that the correct tools are available
- The Contractor shall ensure that all tools are inspected and maintained in accordance with the manufacturer's specifications.
- Contractor Personnel allowed to use their own tools and tool boxes must perform routine tool inspections in accordance with these Instructions.
- Only qualified personnel shall perform the maintenance and repair of hand and power tools.
- TATA Power Solar Systems Limited Representative has the authority to reject any hand or power tools that do not meet the requirements of these Instructions.

Record shall be maintained as per **annexure- 22 a & 22 b**.

### 14.4 Air Operated Tools (Pneumatic)

- Air operated tools shall only be used in accordance with manufacturers' specifications and instructions.
- Eye, hearing, and hand protection shall be used when operating air operated tools together with any other recommended PPE in accordance with manufacturers' specifications and instructions.
- Only hoses and couplings designed for the system pressure shall be used with such device.
- Air hoses ½ inch in diameter or greater will have a safety excess valve installed at the source of the air.
- Clips, whips or retainers are required at each air hose coupling and to prevent attachments from being ejected from the tool.

- Attachments for air operated tools must be designed for that purpose in accordance with manufacturers' specifications and instructions.
- Air operated tools shall only be used with locking pin requirements in place before put into use.
- Air lines and disconnect hoses shall be shut off from headers when not in use

## 15. Ladder Safety

The Contractor shall follow the following rules regarding the use of portable ladders. The Contractor shall provide training to all of Contractor's Personnel on the proper use of portable ladders and the requirements of these procedures.

All ladder shall be inspected and recorded as per annexure - 19

### 15.1 Ladder Requirements

- Portable ladders should only be used when it is not practical or feasible to erect a scaffold.
- Use only heavy-duty type ladders that are approved for the work application.
- Ensure to only use ladders that are long enough or extend far enough for the task.
- Ensure the maximum weight limit allowed for the ladder is adhered to at all times.
- All manufactured ladders must have a minimum 1A Extra Heavy Duty Rating
- When working on or from a ladder at elevations greater than six (6') feet or more above the work surface, such ladders (including stepladders) must be tied, blocked, stabilized by a second worker or otherwise secured against accidental displacement. Where adequate anchorages are available, workers shall tie off using a personal fall arrest system or utilize a different means of gaining access (i.e., scissor lift, scaffold, etc.).
- Ladders will extend past the bearing point no less than 36 inches. Ladder landings shall remain clear of all obstacles and obstruction to follow safe access and egress.

- Contractor Personnel shall inspect ladders daily prior to use. Ladders with broken or bent rungs, steps or side rails will be immediately destroyed and removed from the Site.
- Workers will not stand on the top three rungs of a straight ladder.
- All straight ladders will have non-skid feet at the base.

**Inspections: Before You Start**

- Check the maximum weight limit allowed for the ladder.
- Inspect the ladder before using it. Ensure it is not damaged in any way (e.g. broken, bent or loose members, missing non-slip feet, etc.)
- Tag and remove defective ladders for repair. Destroy ladders that cannot be safely repaired. Do not straighten bent or bowed ladders.
- Make sure your ladder is electrically insulated.
- Make sure that your shoes are not wet or muddy, as this could cause you to slip.
- Place ladders on solid, flat ground.
- All ladders must be secured (tied off) when in use.
- Placement of the ladder must maintain a minimum of one foot from the wall for every four feet the ladder extends up. (See Figure)
- Placement of the ladder must maintain a length such that the side rails extend beyond the top support point by a minimum of 36 inches
- When using mobile tubular ladders, place the ladder as close as possible to the racking structure to minimize reaching. Make sure to lock the wheels.
- Do not lean the ladder against an unsecured backing such as loose boxes or merchandise.
- Portable stepladders must be fully opened and mechanical locking mechanism engaged when in use.
- Extension ladders must maintain a minimum of 36 inches' overlap of both sections of the ladder at all times.
- When using the ladder in front of a door, ensure the door is secured in the open position (tied off).
- Do not increase a ladder's height by standing on an object

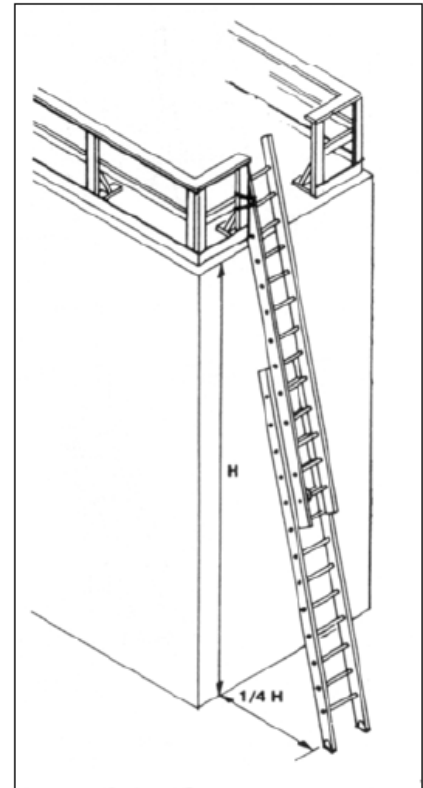

- Only one person is permitted on a ladder at any given time.
- Three-point contact shall be maintained on ladders at all times. Three points of contact means that two hands and one foot or one hand and two feet must be firmly on the ladder at all times.
- If work is performed while standing on a ladder and the fall distance is more than ten (10) feet and three-point contact cannot be maintained, a fall arrest system must be used.
- Straight and extension ladders must be tied off. If this is not practical, the ladder must be held in place by one or more people while in use. Ladder stabilizers on straight and extension ladders are recommended
- When climbing or descending a ladder, grasp the rungs instead of the side rails.
- When using ladders in high traffic areas, adequate barriers must be put in place to prevent individuals, objects or vehicles from coming in contact with the ladder.
- Position the ladder facing your work area. Never work sideways.
- Face the ladder when climbing and descending.
- Climbing with heavy or bulky loads is prohibited. Heavy or bulky loads shall be pulled with a rope or a lift.
- Sliding down a ladder is prohibited.
- Leaping off a ladder is prohibited.
- Never stand higher on a ladder than what the manufacturer recommends (e.g. do not stand on the top step of stepladder and do not stand higher than the third rung from the top on a straight ladder).
- Use of a stepladder as a straight ladder is prohibited.
- Standing on the top or pail shelf of a ladder is prohibited.
- Never walk under ladders. Ensure that the area surrounding the base and top support of a ladder is clear from obstacles and items that may cause people to trip or may hit the ladder.

## 16. Scaffold Safety

Where work cannot be performed from the ground or other safe surface, the Contractor shall provide, or ensure that Contractor's Personnel provides, a scaffold or other means of support that provides an equivalent level of safety.

### 16.1 Scaffold Requirements:

- For large complex scaffold projects, the Contractor shall, or shall ensure that Contractor's Personnel shall, appoint a scaffold Competent Person. This position will be the single point of contact for all scaffold safety requirements.
- The appointed scaffold Competent Person will direct and supervise the erection and dismantling of all scaffolding on the project.
- The Competent Person will sign and attach one of the following color-coded scaffold tags to each scaffold:
  - **Green Tag:** Scaffolding complete and ready for use
  - **Red Tag:** Scaffolding incomplete and not for use
  - **Yellow Tag:** Scaffolding usable but personal fall protection required
- Written inspection logs and a scaffold tagging system shall be implemented for every scaffolding system. Scaffolds shall be inspected by the scaffolding Competent Person (a) daily prior to use and sign the tag at the time of the inspection (b) a minimum of once per week, and (c) upon the completion of any modifications or alterations to a previously approved for use and tagged by the scaffolding Competent Person.
- Contractor shall provide the TATA Power Solar Systems Limited Representative with engineered or typical scaffold design criteria and drawings.
- Scaffolds must be used only to support people and light equipment/tools unless they are specifically designed, engineered and certified for another purpose.
- Before a scaffolding system is put into use, it must be approved for use and tagged as such by the scaffolding Competent Person.
- All scaffolds utilized for rigging purposes must be erected in accordance with engineered drawings for such scaffold. The scaffold Competent Person shall inspect such scaffolding to ensure that the scaffold has been erected in accordance with the engineered drawings. A copy of the engineered drawing shall be attached to the scaffold during the entire duration of the erection.
- Do not erect, use, dismantle, alter, or move scaffolds such that they or any conductive material handled on them might come closer to exposed and energized power lines according to the chart below at a minimum
- Contractor shall ensure that prior to the commencement of each use of the scaffold, inspect the scaffold to



- verify that the scaffold has been approved and tagged, and
- Verify that there is no damage or defects.
- All scaffolds equipped with castors or wheels must have fully functional breaking systems applied to each castor or wheel.
- All scaffolds shall be designed and constructed with swing gates or similar hard barriers at each access point in a manner sufficient to prevent individuals from falling off the scaffold.
- Trap doors used for access must be clearly identified as such and closed when not in use.

## 16.2 Scaffold Inspection and Tagging Guidelines

The Competent Person responsible for erecting the scaffold must inspect the scaffold after erection and before use, which inspection shall include checking the following:

- Scaffold hardware is not defective, and components are compatible and sufficient
- Standard guardrails, toe boards and decking are in place
- Completely planked platforms
- Wheels on mobile scaffolds are locked Ladder in place for proper access
- Locking pins are in place at joint
- No damage to hooks on manufactured platforms
- Scaffolds are sturdy, level, and properly placed on support surfaces.
- Check for proper ties to buildings, where required.
- Scaffold and their components, except for wire or fiber rope suspension must be capable of supporting 4 times the maximum intended load.
- Wire or fiber rope used to suspend scaffolds must be capable of support at least 6 times the maximum intended load.
- If a scaffold is more than 2 feet above or below a level, there must be a way to get on or off — such as a ladder, ramp, or personnel hoist.
- Uprights must be vertical and braced to prevent swaying; platforms must be level.
- Wooden plans are free of splints, knots and dry rot.
- No de-lamination of laminated veneer planks, and planks must be unpainted, so any cracks will show.
- Scaffold platforms and walkways must measure at least 18 inches (0.46 m) wide.
- Counterweights, if used must be made of non-flow able material. Do not use sand, gravel, or similar materials

Scaffolding before green tagging inspection and record as to be maintained as per annexure 18 - a



### 16.3 Fall protection

- If a scaffold is more than 6 feet above ground level, Contractor shall, or shall ensure that Contractor's Personnel shall, utilize proper fall protection.
- The scaffold Competent Person shall determine the most appropriate manner to implement fall protection during the assembly and decommissioning of a scaffolding system.
- All scaffold systems shall include guard rails on all open sides and ends.
- Scaffold walkways must have no gaps between planks and guardrails

### 16.4 Access and Use

- If a scaffold is more than 2 feet above or below a level, there must be a way to get on or off — such as a ladder, ramp, or personnel hoist. This does not apply to swinging scaffolds or those with safe and convenient access from adjacent floors. Do not use cross bracing as a means of access.
- Use personal fall-arrest when needed.
- Wear personal fall protection connected to an independently secured horizontal or vertical lifeline or building structure when working from a suspended scaffold, boatswains' chair, catenary, bloat, needle beam scaffold or any scaffold platform not equipped with standard handrails, mid-rails on all open sides, or complete deck.
- Provide overhead protection for Contractor Personnel on scaffold exposed to overhead hazards.
- Do not change or remove a scaffold unless authorized by the Competent Person responsible for its erection.
- Do not alter scaffold members by welding, burning, and cutting, drilling, or bending.
- Do not combine parts and sections of scaffolding made by one manufacturer with those from a different manufacture
- Keep scaffold platforms and access ways free of tripping or slipping hazards
- Do not use scaffolds during storms or high winds, do not stockpile or store material on scaffolds., Protect scaffolds from trucks and other vehicles contacting them.
- Keep scaffolds clean, with no scrap, loose tools, or tangled lines.
- Do not allow open fires upon or near wooden scaffolds or metal scaffolds with flammable components.

Access Scaffolding before green tagging inspection and record as to be maintained as per annexure 18 b

## 17. Confined Space Entry:

This procedure describes the rules and procedures to protect employees from the hazards of Confined Space entry.

This procedure is developed to cover the safe work practices required for Confined Space Entry. This procedure is developed to establish mandatory requirements for practices to protect personnel from hazards associated in this area. Example: Underground tanks, Pits, Boilers, Ducting and any other enclosed area, etc. that creates conditions that give rise to likelihood of an accident, harm or injury of such nature as to required emergency action due to

- the presence or reasonable foreseeable presence of:
  - flammable or explosive atmospheres
  - harmful gas, fume or vapors
  - free flowing solid or an increasing level of liquid
  - excess of oxygen
  - excessively high temperature
- the lack or reasonably foreseeable lack of oxygen

Actions to eliminate or minimize hazards for the above would be

- Personnel entering confined space entry will be required to have class room/onsite training prior to entry, person entering the confined space should be medically fit
- Permit to work at confined space entry should be obtained from Site HSE personnel's and Risk assessment for confined space and related work shall be carried out and explained to the workmen entering inside the confined space.
- Ensure the confined space is positively isolated for all the source of energy (Hydraulic, Pneumatic, electrical, etc. by use of Lock Out Tag Out (LOTO) System
- Plan the work involving personnel responsible for the preparation (Isolation, depressurization, draining, venting, flushing, Purging, etc.) of confined space
- Proper Barricade to be provided surrounding the confined space entry for unauthorized entry and visual display should be provide.
- Ventilate the toxic gases inside the confined space entry well in advance by opening the manholes for safe working and Ensure the confined space is flushed, purged and thoroughly ventilated as required
- Provide Secured Ladders/Staircase for Entry and Exits points to verify that proper fall protection controls are in place
- Workmen entering the Confined Space should wear Full sleeves shift, Safety Goggles. Safety Shoes, Full body harness & lifeline for retrievals of personnel from inside the confined space area.
- Ensure the confined space is from any flammable/toxic atmosphere and has sufficient oxygen for breathing. Oxygen level to maintain minimum of 19.5% to 23.5%
- Check for the level of Flammable gases or vapors in the confined are is less than 10% of its lower Explosive limit

- Illumination level should maintain at 50 lux
- Place a stand by person at a manhole to maintain the contact with the Entrants.
- Stand by person should be with a communication device to raise the alarm if there is an emergency.
- Confirm and ensure that the communication equipment is working correctly. Fully recharge batteries prior to work beginning
- Power cords used should be fully insulated and shall be protected with ELCB
- Ensure sufficient air circulation and ventilation inside the confined space
- Provide periodic breaks/rests (preferable 1 hrs. once) to the persons working inside the confined space and register the entry/exit of the person
- Drinking water should be available with the person working inside the confined area to overcome body heat and tidiness.

## 18. Work at Height:

This procedure describes the rules and procedures to protect employees from the hazards of working at heights.

This procedure is developed to cover the safe practices required for Working at Heights. This procedure is developed to establish mandatory requirements for practices to protect personnel from hazards associated in this area.

- Work at high elevations where no permanent provision for access or work platforms is available, elevated work on or near unguarded platforms, edges, openings, structures, etc. is hazardous. Such hazardous works have high risks of serious injuries from accidents due to potential of fall hazards. These operations /activities need to be controlled through safety procedures and guidelines, adopting safe work methods and implementing applicable safety standards in work practices to make such hazardous operations/activities safe.
- Proper scaffolds and/or temporary work platforms shall be provided for working at height at elevations 1.5 meters or more where no permanent work platform is available to work safely. The elevated work platforms shall have guardrails and provided with ladders for access/egress.
- Besides the use of a safety full body harness, there is also a need to eliminate the hazards and reduce the risks to an acceptable level; use other required Personal Protective Equipment (PPE).
- Where it is not feasible to erect scaffolds, suitable hydraulically elevated work platforms or portable platform with wheel locks / chokes and guardrails shall be used.
- Ladders shall not be used as work platforms.

- Employees or contractors working on unguarded surfaces, steep slopes and similar locations; temporary platform, during scaffold construction; or when otherwise exposed to the possibility of falls hazardous to life or limb, shall be secured by full body harness with double lanyard.
- Full body harness with double lanyard shall be worn when work requires persons closer than 1.8 meter from roof edge without parapets, or floor opening.
- Full body harness with double lanyard shall be used by persons where work requires persons to move or walk from one place to another for changing work locations at height and where it is not feasible to provide guarded platforms and scaffolds (e.g., pipe racks) so as to ensure one lifeline is always tied with a fixed support. Persons shall always keep one lanyard anchored/tied with the fixed support while walking/moving on unguarded surface/edges or structures. Where ever, appropriate fixed support is not available to anchor lanyard of full body harness, provide lifelines of inspected fiber rope or steel wires to anchor lanyard. In no case free fall of more than 1.8mt shall be allowed.
- Make shift arrangements viz., drums, barrels; chairs, etc. shall not be used as work platform to work at height.
- The intended load must not exceed the maximum working load of portable work platforms.
- Full body harness, which meet IS standard, (IS 3521: 1999) shall be used. Safety belts are prohibited.
- Lanyards must be made from "Dacron" or equivalent polyester rope or web material, or wire rope, and shall be fitted with locking snap hooks and of 1.8 meters in length. Use of other materials requires approval of the location SHE.
- Lanyard should be attached to the D-ring on the back of the harness between the shoulder straps.
- Snap hooks shall be of double locking type
- Fall arresting devices may be used depending on the requirement of situation, i.e. Chimney painting, wall painting, working on the transmission towers, etc.
- Anchor points for fall arresting systems must be capable of withstanding a 5000 lb. (2300 kg) load per person attached.
- Personal Fall Arrest System components must be visually inspected before each use.
- Proper area barricading to prevent people walking across below the working area shall be done before commencing any work at height. If such barricading is not possible, safety net shall be provided and "Work in Progress" boards shall be displayed.
- No working at height shall be carried out without supervision.
- JSA shall be conducted for access & egress from one anchorage point to another anchorage point.

**18.1 Special conditions, above 15 meters, climate**

- When performing man lift operations, all personnel in the personnel basket (platform) must wear a full body doubles harness (class 3) with the lanyard attached to the man lift or permanent structure. Do not anchor a lanyard with personnel platforms (work baskets)
- Work from portable and extension ladders above 1.8 mt. heights from the working/walking surface will require the use of personal fall arrest equipment. The ladders must be secured from moving by tying the ladder to the structure and by using an attendant holding the base of the ladder.
- Temporary platforms and scaffolds should be provided with solid grating (free of openings) and standard guardrails with toe boards attached. Employees working from such completed temporary platforms and scaffolds are not required to wear fall arrest equipment as long as they stay inside the confines of the guardrail system.

**18.2 Special hazards, bees, coconut trees/ any other trees**

- In case of hazard of Honeybees, help from pest control, water spray, steam jet and PVC apron with hood shall be used. Hazard of bird hit and monkey attack is to be considered at high rise tower and prone areas Suitable net/arrangement shall be provided to avoid fall of coconut.

**18.3 Protective equipment**

**18.3.1 Guardrail System:**

- Installation of a Guardrail System around the work area is required for fall protection. Guardrail Systems must meet the following minimum requirements:
- Top rail (handrail) must be 1050 mm / 42 inches plus or minus 3 inches from the working surface. Top rails must be capable of withstanding an expected force which may arise while working.
- Mid rails must be located midway (525 mm / 21 inches) between the top rail and the working surface. The mid rail must be capable of withstanding a force of 150 lbs. (70kg).
- Toe boards will be provided to prevent persons falling off the working surface. Toe boards must be a minimum of 150 mm / 6 inches in vertical height and capable of withstanding 23.00 kg / 50 lbs. of outward force.

- Screens or paneling from the toe board to the mid or top rail will be required when equipment or material is piled higher than the toe board and is capable of being ejected from the working surface to the level below.
- Where gates or openings are required in the guardrail system to facilitate material movement, personal fall arrest or restraint systems must be used.
- All platform / walkway above 4 feet from floor shall be provided with guardrail system.
- Every floor opening into which any person can fall must be guarded by a standard guardrail system or by a metallic grating duly fixed in position.
- Any floor opening, for temporary maintenance work, shall be fixed with proper size cover having sufficient strength.

### 18.3.2 Fall arrest systems

- Fall arrestor system is full body harness with double line lanyard of 1.8 mtr length out of which, one has to go to the fixed anchorage and another one for movement. Shock absorbers are preferred to ascertain adequacy of harness in case of sudden fall. Safety nets are to be provided for protecting from human fall and material fall. Hand tools used while working at height should be securely tied to avoid free fall in case of accidental slippage.
- Rescue equipment set along with a trained rescue team with a rescue plan needs to be made available.
- Personal Fall Arrest System components must be visually inspected before each use.
- Figure -Full Body Harness with work positioning Device

Full body harness shall be inspection and record as per **annexure 23**





Lanyard with twin hook is recommended for securing the full body harness



### 18.3.3. Safety nets

- Whenever it is required to carry out work at height where scaffolding cannot be provided, use of safety net is must.
- All safety net systems shall meet the requirements of Indian Standard (IS: 5175).
- Safety net mesh openings shall have a maximum size of 6 inches x 6 inches and be secured at each crossing to prevent elongation of the opening. All nets must meet IS: 5175 standard.
- Safety nets shall be installed as close as possible to the working level but in no case more than 25 feet below the working level.
- The safety nets shall extend out at least 8 ft. from the side of the open edge.
- Material, equipment and other items that fall into the net are to be promptly removed.
- Safety nets are to be inspected before use and then daily for wear or damage caused by falling materials.
- Safety net installation shall be inspected by the concerned maintenance /construction supervisor.



#### 18.3.4 Warning line systems:

- Warning lines may be constructed with rope, chain or wire and installed 30 inches above the working surface. The supporting stanchions (post, pillar, upright support etc.) must be capable of withstanding 16 lbs. (7.3kg) of force applied horizontally.
- The warning line must be flagged every 6 ft. (1.8Mt) with highly visible material.
- The warning line must be at a distance of a minimum of 6 ft. (1.8Mt) from the roof's edge or fall hazard. Personnel working in the 6 ft. (1.8Mt) area between the warning line and the edge must use a personal fall protection system.

#### 18.3.5 Step Ladders

- If working from a step ladder, with your feet less than 6 feet (1.8Mt) above the floor, use of fall protection equipment is not required, unless working backwards, then fall protection is required.
- If working on a stepladder with your feet 6 feet (1.8Mt) or higher above the floor, fall protection equipment shall be used. If no tie-off point is available, the ladder shall be held by a second person to provide added stability.
- Retractable fall arrester shall be used for climbing as well as coming down the ladder where ever it is required. First the retractable fall arrestor shall be fitted and attached while climbing
- When working from a ladder where harnesses are not being used, the person on the ladder should avoid stretching to reach objects. A rule of thumb is to not stretch so far that your belt buckle is outside the rails of the ladder.
- Ladders shall not be used for jobs where leaning over ladder is required.
- Electrical hazard: Portable metal ladders, and wood ladders with metal reinforcements shall not be used for any electrical work or work in substations, switch yards, power plants, or in any area where contact can be made with energized circuits.
- Maintenance: Provision shall be made for routine inspection and maintenance of all ladders. Broken or damaged ladders shall be promptly repaired or removed and destroyed. Ladders not found in good working condition shall be promptly removed from service until repaired and restored.
- Securing ladders: All ladders shall be placed on firm ground, secured at top and intermediate positions to maintain them rigidly in place and to support the loads imposed upon them.
- Restrictions: Ladders will not be used as work platforms or scaffolding or as structured members of scaffolds or walkways. Ladders shall not be used in horizontal position.

Ladder inspection and record as to be maintained as per annexure 19



**CAUTION**

**Do not carry anything in hand while climbing up or down on a ladder.  
Always ensure three-point contact**

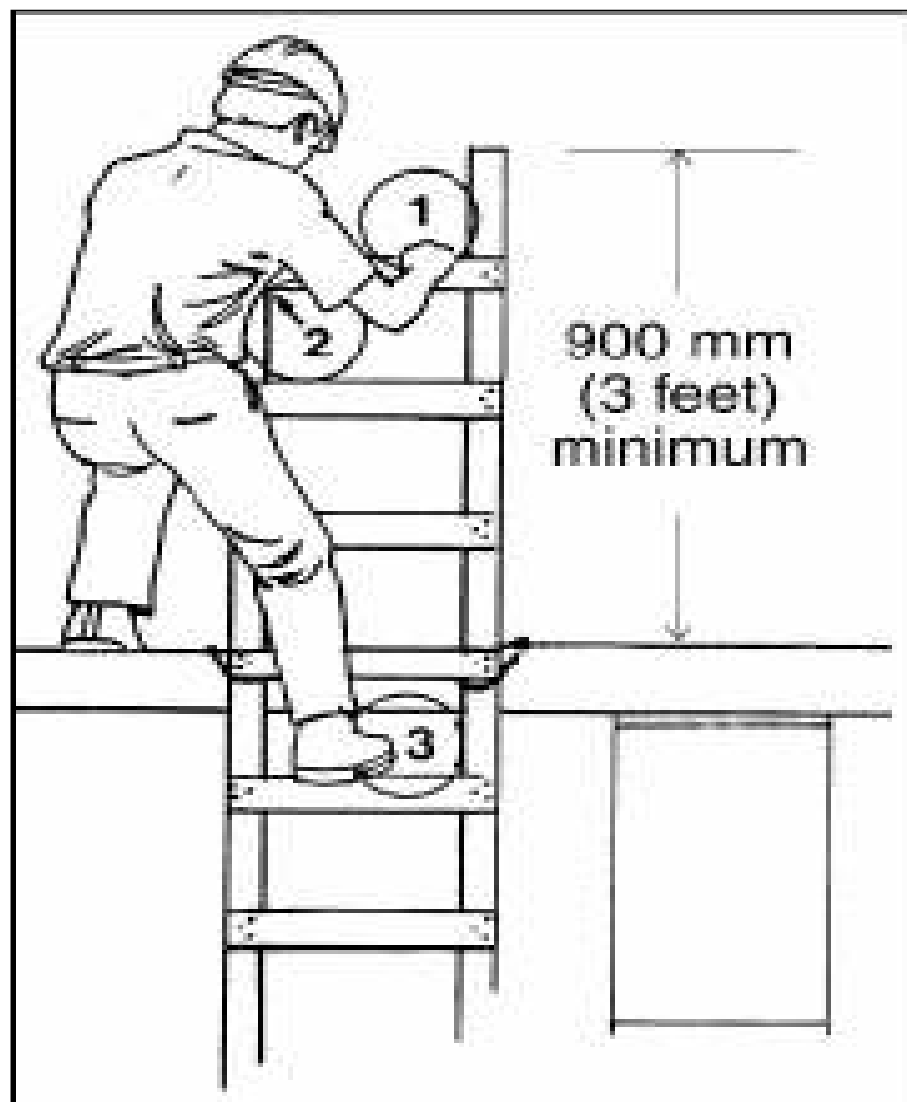
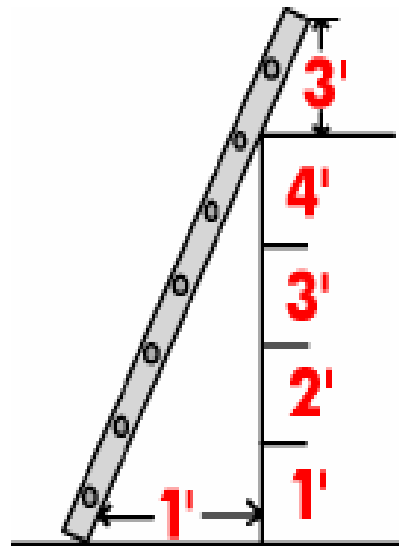

Figure illustrating three-point contact

#### 18.3.6 Straight Ladders, Extension Ladders

- Rung spacing shall not be more than 30 cm.
- All metal parts or fittings of Ladders shall be made of steel, wrought iron,

- Malleable cast iron or other equivalent material.
- Landing platforms shall be provided every 9 m.
- Monkey ladder to cage strip clear distance shall be more than 70 cm
- If monkey ladder length is more than 8' to 10', cage guard shall be provided.
- Ladder shall rise 1 m above stepping point.
- Snap chains shall be provided at the end of landing platform and the ladder.
- If working with your feet 6 feet (1.8Mt) or more above the floor, harnesses shall be used whenever a suitable anchor point is available. If no suitable anchor point is available, the ladder shall be held as in 6.2.5.2 and stretching limited as in above.
- Straight Ladders and extension ladders will be tied off at the top. A co-worker shall always hold straight ladders and extension ladders while the ladder is being tied off. The person on the ladder shall attach their lanyard to the anchor point first before tying off the ladder itself.
- If a straight ladder or extension ladder is being used for access to a work area (as opposed to working from the ladder) where frequent trips up the ladder will be made, consideration shall be given to providing fall protection such as a retractable lifeline or rope grab for those climbing the ladder.
- Face the ladder when working from it. When it is not possible to work facing a ladder or when performing some task requiring both hands, fall protection should be worn and properly anchored.
- Ladder shall be placed as shown in figure below i.e.  $\frac{1}{4}$  th of the working height. (at least 75 deg. to the floor).
- Ladder shall extend 3' to 4' above the point of Landing and topmost 3 rungs shall not be used.



### 18.3.7 Rope Ladders

- The diameter of manila rope shall not be less than 25mm.

- Wooden planks forming steps shall not be less than 38 mm thick.
- Rope ladder made of 12mm nylon rope with 25mm dia. fluted aluminum pipes and with the provision of stop hook at the free end are also available.

## 19. Alcohol and Drug Use

- All Tata Power Solar Work Sites are free from the use of alcohol and the use, possession, or distribution of controlled substances.
- Any Contractor Personnel who is found to be under the influence of alcohol or a controlled substance or who is found to have in his or her possession a controlled substance shall immediately be removed from the TATA Power Solar Systems Limited Site. Such Contractor Personnel shall not be permitted to return to the TATA Power Solar Systems Limited Site by either the Contractor or TATA Power Solar Systems Limited.
- Any such controlled substance may be confiscated and turned over to the appropriate law enforcement agency.
- Contractor shall ensure that Contractor Personnel shall report any controlled substance being used or in the possession of such Contractor Personnel that has been prescribed by a licensed medical doctor prior to permitting such Contractor Personnel from performing any duties at the project Site.

### 19.1 Testing Protocol

- For Alcohol testing will be done using onsite alcohol testing equipment.
- For Drug Contractor Personnel scheduled for testing will report to a certified laboratory location chosen by the TATA Power Solar Systems Limited Representative. The Contractor Personnel will follow the direction of the clinical staff of the laboratory and submit a urine and blood sample for testing.
- The Contractor Personnel will sign a release form and begin a chain of custody for each sample. The chain-of-custody shall be maintained by the laboratory.
- The laboratory will at a minimum test for the following drugs: alcohol, marijuana, opiates, amphetamines, cocaine and phencyclidine.
- All drug test results will be returned to the TATA Power Solar Systems Limited Representative.
- Testing and test results shall be kept confidential by the Tata Power Representative and shall only be disclosed to the Contractor Personnel, the Contractor Personnel's supervisor, and the Contractor.

### 19.2 Positive Test Results



- If a Contractor Personnel has tested positive, he or she shall immediately be removed from the TATA Power Solar Systems Limited Site. Such Contractor Personnel shall not be permitted to return to the TATA Power Solar Systems Limited Site by either the Contractor or TATA Power Solar Systems Limited

## 20. First Aid & Medical Services

This section provides general instruction and guidance concerning first aid/CPR services to be provided by Sun Edison personnel. The Contractor shall, or shall ensure that Contractor's personnel shall, comply with the following requirements

Each Site shall have representative certified in CPR/First Aid. This person shall be identified during the pre-entry daily tailgate meeting, and listed in the Site Specific Health and Safety Plan. Emergency services, however, are provided by local or regional EMS services.

The location and telephone number of the Emergency Services available for the specific Site shall be listed in Tata Power Site-specific Health and Safety Plan.

### 20.1 First Aid Equipment

Each Site shall be provided with first aid kit as per the Requirements below,

Sl no	Item Description	Qty
1	A sufficient number of eye wash bottles filled with distilled water or suitable liquid clearly indicated by a distinctive sign which shall be visible at all times	1
2	4% xylocaine eye drops, and boric acid eye drops and soda bicarbonate eye drops	1
3	Small sterilized dressings	24
4	Medium size sterilized dressings	12
5	Large size sterilized dressings	12
6	Large size sterilized burn dressings	12
7	Sterilized cotton wool. (15 cm.)	12
8	(Two hundred ml.) bottle of cetrimide solution (1%) or suitable antiseptic solution	1
9	(Two hundred ml.) bottle of mercurochrome (2%) solution in water	1
10	(One hundred twenty ml.) bottle of salvolatile having the doses and mode of administration indicated on the label	1
11	Pair of scissors	1
12	Roll of adhesive plaster (six cm. x one mtr)	1
13	Rolls of adhesive plaster (two cms. x one mtr)	2
14	Sterilized eye pads in separate sealed packets.	12

15	Bottle containing hundred tablets (each of three hundred twenty fivemg) of aspirin or any other analgesic	1
16	Roller bandages ten cms. Wide	12
17	Roller bandages five cms. Wide	12
18	Tourniquet	1
19	Splints	1
20	Safety pins	3 packets
21	Kidney tray	1
22	Snake bite lancet	1
23	(Thirty ml.) bottle containing potassium permanganate crystals.	1
24	First-aid leaflet issued by the Directorate General.	1
25	Triangular bandages	6
26	pairs of suitable, sterilized, latex hand gloves.	2

First Aid Kits are to be inspected weekly, and restocked/replaced as soon as possible after items have been used. It is the responsibility of the TATA Power Solar Systems Limited on-Site representative to inspect and maintain these kits.

## 20.2 Medical Services

- Emergency Medical Services are listed in the Site Specific Health and Safety Plan. Non-emergency treatment of serious injuries that require medical attention, but are not life threatening or need the services of EMS personnel, shall be performed at the nearest Hospital or Clinic. Directions to the medical service providers are attached to all Health and Safety Plans.
- Injured personnel ARE NOT to drive themselves to a medical treatment facility. An escort person shall drive the injured person to the nearest facility, and remain at that facility until relieved or released from that responsibility by TATA Power Solar Systems Limited.

## 20.3 Notification / Posting of Information

- Emergency medical services contact information is to be clearly described in Site Specific Health and Safety Plan prior to Site activities.
- During the Pre-Entry Briefing/orientation, Emergency services and contact procedures are to be described and explained to all Contractor Personnel, visitors, and subcontractors prior to entering the Site. This information should be posted in a conspicuous location.
- A map clearly showing route(s) to the nearest medical services facility is to be attached to the Site Specific Health and Safety Plan, and posted in a conspicuous location.

## 20.4 Emergency Action Plan

- The Contractor and each Subcontractor shall develop an emergency action plan



- The Contractor shall develop an emergency evacuation diagram that will show routes of escape and designate emergency assembly areas for Contractor Personnel.
- The emergency action plan will be conspicuously posted throughout the Site and communicated to all Contractor Personnel during safety orientation and weekly safety meetings.
- The Contractor will determine notification process to inform Contractor Personnel that there is an emergency (sounding of an alarm; bullhorn, radio, flashing lights, etc.) and ensure that all Contractor Personnel understand the alarm

#### 20.5 Fire:

- In the event of an emergency, ALL Contractor Personnel shall evacuate the Site immediately and report to the pre-determined assembly area.
- After reporting the fire, Contractor Personnel will evacuate the work area and report to the determined assembly area that was stated during the safety orientation

Mock drill record as to be maintained as per annexure 26 & First Information Report as to be maintained as per annexure 27

## 21. Sanitation

The purpose of this section is to prescribe minimum sanitary requirements. High standards of sanitation must be maintained to ensure the protection of TATA Power Solar Systems Limited employees, Contractor Personnel, and third parties, from potential health problems. Conditions or activities that might serve as avenues for the potential spread of contamination and disease then must be eliminated by the use of established hygienic principles.

The Contractor shall, or shall ensure that Contractor's personnel shall, comply with the following requirements

### 21.1 Housekeeping

All buildings and grounds shall be kept clean and orderly and in a sanitary condition. Basic daily routines should be established to maintain the basics of housekeeping. These should include basic waste removal procedures.

### 21.2 Waste Disposal

- Receptacles constructed of smooth, corrosion-resistant, and easily cleanable or disposable materials should be provided and used for the disposal of waste. They shall

be maintained in a clean and sanitary condition. All receptacles and off-Site waste must be emptied by the end of each shift.

- All sweepings, solid or liquid waste, shall be removed in such a manner as to avoid creating a hazard to health, and as often as necessary or appropriate to maintain the place of employment in a safe and sanitary condition. Dry sweeping shall be limited to the collection of nontoxic or non-hazardous dust. Floors and working surfaces should be kept free of water, grease, oil, and other waste.
- Stored garbage shall be inaccessible to insects and rodents. Outside storage of plastic bags is prohibited unless they are stored in nonabsorbent, leak proof containers with tight-fitting lids.
- Outside garbage storage areas shall be clean and adequate in size. Containers, dumpsters, and compactors shall be stored on a smooth concrete slab or other relatively nonabsorbent surface, maintained in good repair, and kept clean.

### 21.3 Eating Areas

- In every establishment where there is exposure to toxic or hazardous materials, a separate lunchroom shall be maintained unless it is arranged for the Contractor Personnel to lunch away from the premises.
- No food shall be stored or eaten where any toxic materials are present that may contaminate the food in quantities that may be injurious to health.
- Food preparation areas, such as area kitchens and coffee or tea carts, shall be kept clean.
- Food and beverage shall be stored only in refrigerators or storage areas that are designed to exclude contact with toxic agents

## 21.4 Water Supply

### 21.4.1 Potable Water:

- An adequate supply of potable water shall be provided in all places of employment. Drinking water should be made available at any location at which
- Contractor Personnel are regularly engaged in work. Under certain conditions where the work area is large and the number of Contractor Personnel is small, these requirements may be met by the use of portable containers of drinking water.
- Portable containers used to dispense drinking water shall be capable of being tightly closed and equipped with a tap.
- Contractors and Contractor Personnel are responsible for cleaning up around the water container areas.
- Dipping of cups in the container, sorting soda cans and bottles; drinking directly from the spout or placing of hands or material into drinking water are prohibited

#### 21.4.2 Non-Potable Water:

- Outlets for non-potable water shall be posted to clearly indicate that the water is unsafe for drinking, washing, and cooking purposes.
- Provisions shall be made to isolate potable water from non-potable water by physical separation of the plumbing systems or by the installation of backflow prevention devices.
- Non-potable water shall not be used for bathing or washing any portion of persons, clothes, or dishes

#### 21.5 Sanitary Facilities

##### 21.5.1 Toilet Facilities:

- Every place of employment shall be provided with adequate toilet facilities that are separate for each sex, and are readily accessible to all Contractor Personnel
- Under temporary field conditions, provisions shall be made to assure not less than one toilet facility is available. Each Site that is not serviced by a sanitary sewer shall be provided with one of the following toilet facilities:
  - Privies (where their use will not contaminate ground or surface water);
  - Chemical toilets
  - Re-circulating toilets
  - The requirements for sanitation facilities shall not apply to mobile crews having transportation readily available to nearby toilet facilities

##### 21.5.2 Hand Washing Facilities:

- Each place of employment shall be provided with adequate, conveniently located hand- washing facilities for its Contractor Personnel. A minimum of one washing station provided to comply with this requirement shall at all times:
  - Be equipped with hot and cold or tempered running water, dispensed with a mixing faucet;
  - Be maintained in a clean and sanitary condition;
  - Have an adequate supply of water for effective washing;
  - Have a readily available supply of soap or other suitable cleansing agent;
  - Have a readily available supply of single-use towels or a warm-air blower;
  - Be located and arranged so that any time a toilet is used, the user can readily wash.

## 22. Pre-Employment and Periodic Medical check up

Contractor shall arrange to conduct a pre-employment and periodic medical check-up for its entire workforce by authorized medical officer. The contractor shall be able to produce the certificate prior to the employment. The contractor shall also organize to conduct periodical medical checkup (six monthly) for the following category of employees:

- Drivers (Check for Vision & Hearing)
- Equipment Operators (Check for Vision & Hearing)
- Workforce working at Height (Check for Vision, Hearing, Vertigo & Height Phobia)
- Workforce Handling the hazardous substances (Coal, ash and chemicals)
- Workforce in high decibel area (> 90 Decibel, Check for Hearing)
- Workforce, working in specific areas requiring specific medical attention should conduct the medical test as laid down in the respective Site Safety Management Plan.

## 23. Training

Safety Training and capability building of workforce is a major component of safety management program. All training required must be provided and documented as specified by TATA Power Solar Systems Limited and Indian Regulations. TATA Power Solar Systems Limited Safety Manager will audit contractors training and related documentation to assure its adequacy.

### 23.1 TATA Power Solar Systems Limited Site Safety Orientation

All TATA Power Solar Systems Limited contractor and subcontractor workforce is required to attend Safety Orientation Training to receive a Safety Training Card, which is required to obtain a Gate Pass to the site, prior to entry.

This Safety Orientation Course will be for duration of minimum 4 hrs. The information provided during the orientation will include, but is not limited to following:

- Job rules, personal safety and conduct
- Hazards reporting
- Reporting of injuries
- Emergency procedures
- Safety Activities and Program including disciplinary measure and incentives.
- Critical safety procedure relevant to the job

### 23.2 Regular Safety Training:

Contractor shall ensure that concerned workmen are provided with adequate training before he/she is allowed to execute the work and also ensure that regular training is carried out as per TATA Power Solar Systems Limited Training plan.

Record as to be maintained as per **annexure 31**

## 24. Workers Accommodation Requirement

This section covers key aspects that are to be taken into consideration, which includes the general living facilities, rooms/dormitories facilities, sanitary facilities, medical facilities and leisure/social

### 24.1 Room/Dormitory Facilities

- Rooms shall be properly ventilated and cleaned at regular intervals. All living rooms must be
- Provided with windows the total of which must be not less than one-tenth of the floor area. At least one-half of each window must be so constructed that it can be opened for purposes of ventilation. Each room used shall be at least from 10 to 12.5 cubic meters (volume) or 4 to square meters per person. A minimum ceiling height shall be 2.40 meters. Sanitary facilities shall be located near the rooms.
- Guidelines for Construction: Quality of materials, construction methods, and nominal resistance to natural calamities shall be ensured. Fire resistance materials should be used. Asbestos material shall be prohibited for usage in any part of construction. Relevant insulation materials shall be provided to prevent the ingress of extremities in weather condition for both heat and cold all doors and windows shall be lockable.

### 24.2 Water Supply

- Adequate and potable water must be provided for drinking, cooking, bathing and Laundry purpose
- The distribution lines must be capable of supplying water at normal operating
- Drinking water must meet potable drinking water standards and water quality must be monitored regularly.

### 24.3 Lighting

- While setting up any electrical set up precautions to be taken right from initial set up
- Stage till functioning phase. Standard material shall be used for any electrical
- Installations equipped with tripping device and circuit breakers.

### 24.4 Toilet Facilities

- An adequate number of toilets shall be provided to workers, 1 unit per 6 persons.
- For urinals, usual standards are 1 unit to 15 persons. Toilet facilities shall be conveniently located and easily accessible. All toilet rooms shall be well-lit, have good ventilation, sufficient Hand wash basins and be conveniently located.
- Separate toilet rooms must be provided for each sex. Each toilet room must be lighted naturally or artificially by a safe type of lighting at all hours of the day and night. Toilets must be cleaned daily and hygiene condition should be maintained.

## 25. Waste Management

This section covers feasible measures to be taken for managing and disposal of waste generated at work location.

### 25.1 Waste Categorization & Segregation:

Waste generated shall be segregated into following categories:

1. **Non Hazardous waste:** waste containers (other than used oil / paint containers etc.,) domestic dry waste such as paper and plastics, packaging materials, wooden and structural scraps, wastewater etc.
2. **Hazardous waste:** Includes used batteries, cables, fire-fighting foam, adhesives, general chemicals, acids, oily rags and absorbents, solvents, contaminated soils, insulation, paint sludge, used oil and paint cans and drums, electrical components etc..
3. **Organic waste:** Includes food waste, wastewater and other organic wastes like grass, leaves etc.

4. **Bio-Medical waste:** All Waste generated from first aid center like, Items contaminated with blood, and body fluids including cotton, dressings, soiled plaster casts, lines, beddings, wastewater etc...

### 25.2 Collection & Transportation of Waste:

All wastes generated should be identified and segregated as per their nature in order to classify the wastes into nonhazardous, hazardous and organic wastes. Separate bins for each category of wastes and mutually incompatible hazardous wastes shall be kept separately from each. These wastes from bins should be collected from site at regular intervals and shifted to common waste storage area.

Color Coding for waste collection bins

- **Green** – Food waste/Biodegradable wastes
- **Blue** – Non-hazardous/Recyclable wastes
- **Red**– Hazardous wastes

### 25.3 Treatment & Disposal:

#### Non-Hazardous Waste

1. Uncontaminated hard waste such as dirt, bricks, concrete etc. shall be disposed in a municipal solid waste landfill or suitable disposal location identified by the client or through certified agencies.
2. The hardened concrete and bricks may be used as clean fill material at site, if possible.
3. Wastes like wooden scrap and structural steel scrap should be recycled or given to scrap handlers.
4. Wastes like cardboard, paper and plastic should be given to recycler.

#### Hazardous Waste

1. When any hazardous substance is procured, used, stored, or disposed, Material Safety Data Sheet (MSDS) for the substance shall be available at the worksite.
2. Hazardous waste need to be disposed according to recommendations of material safety data sheet or as per local regulations.

#### Organic Waste

1. Food waste generated should be given to local municipality or disposed at suitable location.
2. Wastewater generated shall be treated at STP to meet the standards prescribed by pollution control board. If STP is not available at site then the wastewater generated should be given to local municipality or other arrangements shall be made for disposal of wastewater without causing damage to environment and meet local legal requirement.



#### 25.4 Records:

Waste Management data shall be maintained as per Annexure-13

## 26. Prevention of Pollution

This procedure outlines the methodology to be adopted for monitoring environmental parameters so as to mitigate or minimize the impact or adverse effect on environment and people working in and around the site

### 26.1 Prevention of Air Pollution

#### Dust Control

HSE manager monitors visually the dust level in the working area / project site during the HSE Inspections. If the dust level is found to be abnormal then initiates necessary action for dust suppression. The following dust suppression method shall be adopted according to the area/situation:

1. Water is sprayed on the roads at regular intervals to minimize dust due to vehicular movement and wind blowing.
2. Prior to start of construction operations like Demolition, Crushing, Chipping etc. water is sprayed in small quantities to control dust.
3. Dumpers carrying excavated soils shall be covered with polythene sheets to avoid dust due to high velocity air currents during transportation.

#### Emission Control

1. The stack height of the Diesel Generator Sets shall be as per Central Pollution Control Board Regulations, the extract of which is given below.
2. All vehicles used at site should have "pollution under control" certification.
3. All equipment which uses fuel as energy source should be checked for fuel combustion efficiency.

The minimum height of stack to be provided with each generator set can be worked out using the following formula:

$$H = h + 0.2 \times \sqrt{\text{(KVA)}}$$

H = Total height of stack in meter

h = Height of the building in meters where the generator set is installed

KVA = Total generator capacity of the set in KVA

Based on the above formula the minimum stack height to be provided with different range of generator sets may be categorized as follows:

Generator Sets	Total Height of stack in meter
50 KVA	Ht. of the building + 1.5 meter
50-100 KVA	Ht. of the building + 2.0 meter
100-150 KVA	Ht. of the building + 2.5 meter
150-200 KVA	Ht. of the building + 3.0 meter
200-250 KVA	Ht. of the building + 3.5 meter
250-300 KVA	Ht. of the building + 3.5 meter

### 26.2 Prevention of Noise Pollution

1. Diesel Generator Sets shall be provided with acoustic enclosures to limit the noise generated within safe limits.
2. All equipment used at site should have noise level within safe limits as prescribed by pollution control board /MoEF.
3. Noise producing equipment /machines shall be provided with mufflers/silencers to suppress the noise.
4. Providing warning signs in the noise hazard areas.

### 26.3 Prevention of Land Pollution

The following precautionary measures shall be taken to prevent land pollution due to accidental spillage

1. The floor of the storage area & the collecting drains shall be of Plain Cement Concrete (P.C.C) with an impermeable layer such as Polythene sheets below it.
2. The slope of the floor shall be 1:80 to enable easy flow of spillage oil into the collecting drain.
3. The spillage oil in the drain shall be collected and sent for recycling or disposal as per local regulations.
4. D.G sets should be provided with P.C.C and drip tray.
5. Paint/Chemical storage area should be provided with P.C.C flooring

### 26.4 Records:

Waste Management data shall be maintained as per Annexure -14

## 27. Consequence Management Policy for Contractor

### 27.1 Introduction:

We at Tata Power Solar believe that our contractors are our greatest assets and their safety is of the utmost importance. In our journey towards attaining zero harm/injuries/accidents, we have implemented best in-class safety systems, standards and procedures. The successful implementation of these standards and procedures require demonstrated management commitment and behaviors at all levels, which are consistent with our Safety Principles, in particular, "Working safely is everybody's responsibility and a condition of employment". Safety is a critical requirement as per contract terms & conditions.

### 27.2 Objective:

The Consequence Management Policy (Safety) establishes the process of corrective counseling and disciplinary actions in response to safety misconduct or violation in alignment with the Safety Acts/Rules applicable to the Company.

In the event that the desired safety behaviors are not demonstrated, then the provisions of the Consequence Management Policy (Safety) shall apply.

### 27.3 Scope:

This Policy is applicable to all contractors & sub-contractors of Tata Power Solar.

### 27.4 Definitions:

Any act which is inconsistent with the fulfillment of express or implied requirement of Safety Acts/Rules applicable to the Company.

Any breach of an express or implied duty on the part of the employee.

- Slips are unintended actions
- Lapses are unintended failures to act
- Mistakes are intended, but not what was really meant
- Violations are known failures. Violations can be seen as a form of mistake

#### 27.4.2 Intent behind the violation:

An unplanned or an unusual event, or a series of events and circumstances that resulted in, or had the potential to result in, an adverse or undesirable safety, process safety, health, fire and environmental consequence. Undesirable consequences related to HSE, incidents include, but are not limited to the following:

- Injuries/illnesses

- Significant environmental impact
- Unfavorable impact on the public
- Significant property damage
- Business interruption
- Damage to Reputation

**27.5 Dealing with violation(s) – reactively:**

**Root cause(s) of incident:**

Root cause(s) of the incidents are graded in three categories. The incident investigation report will indicate the exact root causes for each incidents based upon which the disciplinary actions shall be initiated.

**Human Factors:**

Unsafe acts by employee i.e. not following procedure, not using correct (fit for purpose) tools / equipment, not using protective equipment / methods and inattention / lack of awareness and knowledge of safety standards.

**Physical Factors:**

Unsafe conditions / situation created by individual or group of personnel, which, if it continues, can lead to an incident such as by pass or overlooked protective systems, use of defective or improper tools, equipment & vehicles, work with energized system, inadequate work place environment etc.

**System Factors:**

Management failure such as inadequate communication, inadequate work rules / policies / standards / procedures, inadequate provision of tools & equipment, inadequate work planning, inadequate management / supervision / employee leadership, inadequate training / knowledge transfer etc.

**Loss / Potential loss (Severity)**

Severity of loss or immediate potential loss arising from the violation is graded in five levels as indicated in OH&S Risk Assessment Matrix (RAM) below:

### OH&S Risk Assessment Matrix (RAM)

<b>Probability</b>	<b>Very high</b> Almost certain, it will occur >80% in any time frame	(3) <b>Medium</b>	(4) <b>High</b>	(4) <b>High</b>	(5) <b>Very High</b>	(5) <b>Very High</b>
	<b>High</b> Expected to occur 10 % to 80 % chance in time frame	(2) <b>Low</b>	(3) <b>Medium</b>	(4) <b>High</b>	(4) <b>High</b>	(5) <b>Very High</b>
	<b>Medium</b> It could occur less than up to 10 % chance in time frame	(2) <b>Low</b>	(2) <b>Low</b>	(3) <b>Medium</b>	(4) <b>High</b>	(5) <b>Very High</b>
	<b>Low</b> Not expected to occur less than .1 % in time frame	(2) <b>Low</b>	(2) <b>Low</b>	(3) <b>Medium</b>	(3) <b>Medium</b>	(4) <b>High</b>
	<b>Very Low</b> Almost certain it will occur greater than .01% chance in time frame	(1) <b>Very Low</b>	(2) <b>Low</b>	(2) <b>Low</b>	(3) <b>Medium</b>	(3) <b>Medium</b>
		Very Low 1	Low 2	Medium 3	High 4	Very High 5
	<b>Consequence Severity Increases</b>					
<b>Consequences in various regimes</b>	People (Health and Safety)	No Health / Injury risk	First aid cases or slight health problem	Lost time injury or potential health problem	Partial disability or major health problem	Total disability / fatality (s) server healthy problem
	Environmental	Negligible effect confined to in plant grounds / environment	Minor effects neighbors adjacent to plant complain	Localize rerelease makes local TV coverage / news paper	Major release make national TV coverage / news paper	Massive damage makes international TV coverage / new paper
	Product or Service Quality	Some product or service fails to meet standards	Several costumer complain verbally	Several customer complain in writing	Important / major customer cancelled orders	Loss of substantial marked share due problem
	Assets or finance loss	Slight damage is Up to Rs 10,000	Noticeable damage between Rs 10,000 to 1 Lakh	Large damage 1 Lakh to 10 Lakhs	Major damage 10 Lakhs to 100 Lakhs	Severe damage more than 1 Crore
	Reputation (Local, National, or International)	Slight to moderate impact	Loss of community reputation	Loss of state reputation	Loss of national reparation	Loss of international reputation



**Contractor Health, Safety &  
Environment Management System  
( CHSEMS )**

Doc. No.	CHSEMS / A3
Issue date	20/11/2020
Rev # & date	10 -20/11/2020

**27.6 Dealing with violation(s) – Proactively:**

Within Tata Power Solar, potential Safety violations are identified proactively through safety inspections, audits, Safety Observation & Conversation (SOC), Safety Walk (SW), Yellow Card (YC), etc. and the reports are generated. Based on the severity and intention of findings, the fact-finding committee shall initiate disciplinary actions.

**27. 7 Guidelines for Implementation:**

**Step 1 – Fact Finding:**

The Divisional Head / Unit Head shall appoint a team to establish the facts related to the incident including the circumstances leading to the safety violation(s)

- Minimum of 3 members in a team
- Departmental head shall lead the team
- Site/Plant HSE in-charge shall be involved, if needed

The Functional Head/Unit/Project Head shall establish the facts related to the incident including the circumstances leading to the safety violation.

**Step 2 – Evaluation:**

**Intent behind the violation:**

In determining the appropriate root causes behind the violation, the team shall consider the following factors:

<b>Level of Intent</b>	<b>Description</b>
I -1	Unintentional non-compliance Lacks the knowledge of safety standards and the accompanying hazards
I -2	Rare / Exceptional violation Has good knowledge of the safety standards and the accompanying hazards but violated due to work exigency, pressure from peers and supervisors
I -3	Routine violation - Frequent, known and condone Has fair knowledge of safety standards and the accompanying hazards but violated due to routine activity without thought
I -4	Situational violation - Adapting to the problems in the workplace Have good knowledge of safety standards and the accompanying hazards but violated due to work place constraints (lack of resources, tools, equipment etc.)
I -5	Optimizing violation - Doing things better, for kicks Has good knowledge of safety standards and the accompanying hazards but violated due to over confidence, to save time, avoid discomfort, to gain attention, etc.

**Loss/Potential loss (Severity)**



**Contractor Health, Safety &  
Environment Management System  
( CHSEMS )**

Doc. No.	CHSEMS / A3
Issue date	20/11/2020
Rev # & date	10 -20/11/2020

In determining the appropriate level of severity category (i.e. very low, low, medium, high or very high) of the loss and / or potential loss arising from the violation, the team shall consider the following factors:

Level of severity	Description
S -1	No Health / Injury risk, Negligible effect confined to in plant grounds / environment, Some product or service fails to meet standards, Slight damage is Up to Rs. 10,000 and Slight to moderate impact on reputation
S -2	First aid cases or slight health problem, Minor effects neighbors adjacent to plant complaints, Several customer complaints verbally, Noticeable damage between Rs. 10,000 to 1 Lakh, Loss of community reputation
S -3	Lost time injury or potential health problem, Localize rerelease makes local TV coverage / newspaper, Several customer complaints in writing, Large damage Rs. 1 Lakh to 10 Lakhs, Loss of state reputation
S -4	Partial disability or major health problem Major release make national TV coverage / newspaper, Important / major customer cancelled orders, Major damage Rs. 10 Lakhs to 100 Lakhs, Loss of national reparation
S -5	Total disability / fatality (s) server health problem, Massive damage makes international TV coverage / newspaper, Loss of substantial marked share due problem, Severe damage more than Rs. 1 Crore, Loss of international reputation

**Step 3 - Recommended disciplinary action - Based on step 1 and 2:**

The team will recommend the appropriate disciplinary action for individual, group or contractor as appropriate as per following table to Divisional Head

<b>Intent</b>	I - 5	V - 3 M	V - 4 H	V - 4 H	V - 5 VH	V - 5 VH
	I - 4	V - 2 L	V - 3 M	V - 4 H	V - 4 H	V - 5 VH



I - 3	V - 2 L	V - 2 L	V - 3 M	V - 4 H	V - 5 VH
I - 2	V - 2 L	V - 2 L	V - 3 M	V - 3 M	V - 4 H
I - 1	V - 1 VL	V - 2 L	V - 2 L	V - 3 M	V - 3 M
	S - 1	S - 2	S - 3	S - 4	S - 5
<b>Severity (S)</b>					

Legend		Financial Penalty (Rs)
VL	Very Low	500/-
L	Low	1,000/-
M	Medium	2,000/-
H	High	5,000/-
VH	Very High	10,000/-

Severity	Level of disciplinary action				
	Counseling	Warning Letter	Financial Penalties	Suspension for 1 Week	Termination
VL	Yes		Yes		
L	Yes		Yes		
M		Yes	Yes		
H		Yes	Yes		
VH		Yes	Yes	Yes	

**27. 7 Guidelines for Implementation - (Safety Violations):**

Sl. No	Violations of Safety code of conduct	Severity
1	Working without Permit-to-Work (PTW) for activities that is listed in Appendix 2 of PTW procedure	<b>VH</b>

2	Non-compliance of the Lock out Tag out (LOTO) procedure	<b>VH</b>
3	Not confirming isolation before beginning of work on all rotating and electrical equipment or any system that may have and use the specified life-protection equipment	<b>VH</b>
4	Defeating or overriding safety-critical trips or interlocks without obtaining proper authorization	<b>VH</b>
5	Smoking in the notified „No Smoking” areas	<b>VH</b>
6	Specified fall-prevention equipment not used when working at height	<b>VH</b>
7	Operated any machinery / powered equipment without formal training and registered authorization to operate	<b>VH</b>
8	Not wearing seat belt in a moving vehicle, including rear seat where fitted	<b>VH</b>
9	Using mobile phone while driving a motor vehicle or working with mechanized equipment	<b>VH</b>
10	Driving or working under the effect of drugs or alcohol	<b>VH</b>

**Violation: Non-usage of PPE as per TATA POWER SOLAR PPE mandate**

11	Industrial Safety Helmet	<b>L</b>
12	Rider’s Crash Helmet	<b>L</b>
13	General purpose hand gloves	<b>L</b>
14	Safety Goggles	<b>L</b>
15	Industrial Safety Shoes / Boots	<b>L</b>
16	Face Shield (Welding / Cutting)	<b>M</b>
17	Chemical handling suit	<b>H</b>
18	Arc suit	<b>H</b>
19	Full body harness & Safety lifeline at sheet roof	

**Violation: Unsafe Condition**

20	Vehicle not meeting Tata Power Solar Vehicle standard as stipulated in vehicle inspection check list	<b>M</b>
21	Mobile lifting equipment i.e. Crane, hydra etc. not meeting Tata Power Solar lifting equipment standard as stipulated in inspection check list	<b>M</b>
22	Confined Space not meeting Tata Power Solar confined space standard as stipulated in confined inspection check list	<b>M</b>
23	Excavation not meeting Tata Power Solar excavation standard as stipulated in excavation inspection check list	<b>M</b>



**Contractor Health, Safety &  
Environment Management System  
( CHSEMS )**

Doc. No.	CHSEMS / A3
Issue date	20/11/2020
Rev # & date	10 -20/11/2020

24	Gas cylinders not meeting Tata Power Solar gas cylinders standard as stipulated in gas cylinder inspection check list	<b>M</b>
25	Hand tools not meeting Tata Power Solar hand tools standard as stipulated in hand tools inspection check list	<b>M</b>
26	Housekeeping not meeting Tata Power Solar housekeeping standard as stipulated in housekeeping inspection check list	<b>M</b>
27	Machines not meeting Tata Power Solar machine safety standard as stipulated in machine safety inspection check list	<b>M</b>
28	Power operated hand tools not meeting Tata Power Solar power operated hand tools standard as stipulated in power operated hand tools inspection check list	<b>M</b>
29	Personal protection Equipment (PPE) not meeting Tata Power Solar personal protection Equipment (PPE) standard as stipulated in personal protection Equipment (PPE) inspection check list	<b>M</b>
30	Scaffolding not meeting Tata Power Solar scaffolding standard as stipulated in scaffolding inspection check list	<b>M</b>
31	Temporary Electrical Supply not meeting Tata Power Solar temporary electrical supply standard as stipulated in temporary electrical supply inspection check list	<b>M</b>
32	Welding machine not meeting Tata Power Solar welding machine standard as stipulated in welding machine supply inspection check list	<b>M</b>
33	Winch not meeting Tata Power Solar winch standard as stipulated in winch inspection check list	<b>M</b>
34	Housekeeping not meeting Tata Power Solar housekeeping standard as stipulated in housekeeping inspection check list	<b>M</b>
35	Portable ladder / platform not meeting Tata Power Solar portable ladder / platform standard as stipulated in portable ladder / platform inspection check list	<b>M</b>

**Violation: Unsafe Acts**

36	Sleeping at Work Place	<b>L</b>
----	------------------------	----------

**Violation: Traffic**

37	Driving beyond speed limit	<b>M</b>
38	Driving without license	<b>H</b>
39	Over taking above speed limit / at no overtaking area	<b>H</b>
40	Wrong Parking / Wrong Side Driving	<b>L</b>

**27.8 General Guidelines:**

- All the records of disciplinary actions shall be maintained in vendor file at HSE and HR & Admin Department.
- Financial penalties shall be charged to main contractors.
- For repeated violations, the next level of disciplinary actions shall be initiated.
- HR & Admin, Maintenance Department and Other respective departments shall provide a monthly report of disciplinary actions taken to HSE Department.
- It is incumbent upon every employee including contractor to report safety incidents in which they are involved or which come to their notice. Withholding, non-reporting or manipulation of safety incidents and related information / data is an offence which will be viewed seriously and strict disciplinary action will be taken for such an offence including termination of service / contract.
- All unsafe conditions identified through safety inspections are classified as "M" because it can be addressed proactively before an incident.
- The company reserves the right to take the circumstances of the rule breaking / violation into account to determine the disciplinary actions to be taken.

Consequence to Management record as to be maintained as per annexure 32

## 28. Tools, Tackles & Lifting Equipment's Inspection

### 28.1 Pre deployment Inspection:

- All lifting tools, tackles & lifting equipment should have certificate from competent person.
- All lifting tools & tackles should be inspected by Tata Power solar HSE representative at site.
- The observation shall be documented and ensures defective materials are not being issued.
- Inspection team records their findings in suitable checklists.

### 28.2 Periodic Inspection:

- The contractor shall maintain a database for all tools and tackles.
- From the compiled list HSE representative will prepare a schedule and arrange periodic inspection through Site engineer.
- The inspection team submits the observation and recommends corrective action.
- Defective tools and tackles are removed from service and the same gets updated in the stores document.
- HSEO shall prepare the report and shall escalate the matter in case of any non-compliance.

### 28.3 Inspection of Tools, tackles & Lifting equipment's by Competent Person:

- Contractor shall Organize Inspection of all tools, tackles & Lifting equipment's by competent person with frequency at least once in a year or as per the legal requirement.
- Contractor shall Intimate HSE and Site Engineer to witness Inspection of tools and tackles by the competent person.

Inspection and record as to be maintained as per **annexure 15 & 16**

## **29. Construction Blasting Method Statement**

### **29.1 Construction Blasting**

Construction blasting is often conducted close to population centers and requires special considerations for fly rock management. During the planning and design stage, possible environmental impacts due to fly rock, ground vibration, air blast, fume, and dust should be evaluated. A successful blast design is based on a thorough review of such items as rock properties, geology, specification of material to be blasted, and environmental constraints.

### **29.2 Mitigating technique**

Fly rock is caused by a mismatch of the distribution of explosive energy, confinement of the explosive charge, and mechanical strength of the rock. Proper blast design, knowledge of local geology, and use of blasting shelter play an important role in preventing fly rock accidents.

### **29.3 Blast design:**

Proper blast design is the single most important tool to prevent blasting problems, like flyrock. A blast designer optimizes the balance between rock properties, explosive energy distribution, and explosive energy confinement.

### **29.4 Geology:**

Geology plays an important role. Mud seams, voids, joints, extended cracks, and fissures may cause potential problems.

### **29.5 Pre-drilling inspection:**

- The blaster should inspect the highwall face and bench top prior to marking the location of new blast holes.
- Explosive loading and/or blast hole location should be altered to compensate for any irregularities observed during the inspection.

### **29.6 Driller-Blaster communication:**

- Driller's log should be completed during the drilling process and examined by the blaster prior to loading to locate any abnormality or irregularity.
- The log should indicate items such as the depth and angle of each hole, location of voids, competency of rock, loss of air, and/or lack of drill cuttings.

### **29.7 Pre-loading inspection:**

- All blast holes should be checked for depth, inclination, and water prior to loading any explosive.
- Blast holes should also be checked for any obstructions or caving.
- Any void or cavity should be filled or plugged.
- Small voids should be filled with stemming material and large voids should be plugged. This will prevent loading excessive explosive in a blast hole and thereby avoid adverse effects.
- Blast holes often deviate from the planned inclination, causing too much or too little burden.

### **29.8 Loading and firing:**

The loading should be done under the supervision of the blaster. Before loading begins all unnecessary personnel and equipment's should leave the site. The sequence of loading the blast holes should match the approved firing sequence. The blaster or a designated employee should check for both the amount of explosive material and the rise of explosive column in the blast hole during the loading process. This is particularly important for incompetent rocks. Decking height and stemming length must be checked. Insufficient or poor quality stemming could lead to stemming ejection, fragmentation of the collar zone, and fly rock.

### **29.9 Post- firing inspection:**

The blaster should inspect the muck pile for undetonated explosives and the newly created highwall from a safe distance before approaching the area. If no problems are detected, the blaster should approach the area carefully and examine for any abnormal fragmentation, back break, overhang, bootleg, cut-off charge, and misfire.

## **29.10 Sequence of Operation**

### **29.10.1 Rock breaking by tools for**

1. Clearly identify the work area and demark.
2. Use pneumatic tools like tractor mounted compressor, for small quantum of rock chipping or partial rock bed chipping, or for smaller size foundations like cable trench, drain work.
3. Poclain attached rock breaker to be used for higher depth and bigger size of foundations for higher quantum of work.



4. Loose mass of rock, excavated is to be removed from pit with help of Excavator / Poclaim Bucket. Subsequent layer of excavation is to be continued till the required depth is reached.
5. During work progress, precautions need to be taken, so that excess depth than drawing / design is not executed nor undulated surface is left with, at the end.
6. Excavated rocks to be carted away by tractor / dumper and disposed off not usable, to the designated areas.

### **29.10.2 Rock Breaking by blasting**

1. Clearly identify the work location for rock breaking and secure the work area.
2. Blasting time to be notified and to be communicated in daily tool box meeting, when planned in advance.
3. According to size and depth of expected rock mass, number of drill points, diameter of each drill, depth of bore pit to be prepared to avoid over/under sized excavation of control blasting.
4. Ensure Licensed blaster is only engaged for performing the Control blasting work
5. Bore pits needs to be cleaned before putting chemicals in and properly plugged and sealed after placing of chemical into bores.
6. As a precautionary measure, blasting to be done during "Confined work time" i.e. as stipulated in local authority permits. Before charging of pit, security to be alerted and ensured that no people are there in the surrounding the area.
7. Before proceeding with blasting communication to all concerned and working people in and even around site is notified by SIREN at time of blasting and caution thru RED FLAG.
8. After blasting, all the points, trigger for blast need to be checked and confirmed by the blaster so as to ensure that all the charged points are blasted and no pit / location is left over, live and yet to blast at any point of time.
9. Pit needs to be cleared off, from debris before any further blasting is processed onward, for additional depth if any.
10. Debris need to be disposed of to a place, designated by the client, to avoid re-handling

## 30. Incident Investigation and Reporting Protocol

### 30.1 INCIDENT CLASSIFICATIONS & DEFINITIONS

Type of Incident	Description
Unsafe Act	Performance of a task or other activity that is conducted in a manner that may threaten the health and/or safety of workers. For example: Lack of or improper use of PPE. Failure to lockout tag out/. Operating equipment at unsafe speed etc..
Unsafe Condition	A condition in the work place that is likely to cause property damage or injury. For example: Defective tools, equipment, or supplies, Inadequate supports or guards, Inadequate warning systems, Poor housekeeping, etc..
Near Miss	Is an undesired event that, under slightly different circumstances, could have resulted in harm to people, damage to environment or property, or loss to process
First aid cases	A work-related injury or illness that undergone a onetime treatment by either medical professional or by any trained first aider and the injured person able to continue his work on that shift when incident occurred or the next day shift, without any working day lost.
Medical Aid cases	A work –related injury or illness, during which victim was referred to the external hospital for detailed investigation by the doctor or other licensed health care professional and after treatment is advised to resume his / her normal duties. Then it will be considered as a MEDICALLY TREATED injury and not a FIRST AID case and not a LOST TIME injury
Restricted work case Incidents	A work – related injury or illness, during which victim was given a first aid or medical aid treatment and returned back to office, but unable to do his/her routine job and restricted to some limited job is defined as Restricted work case incident
Lost time Incident (LTI)/ Recordable Lost time incident (As per IS 3786 & Indian Factories	A work related injury or illness that causes the injured person to be away from work for at least one normal shift after that on which the injury occurred, because he/ she is unfit to perform any duties. (Eg.) if Mr. X while working in A shift on 25.12.11 met with an accident at 10.30 AM, He might have treated by the company doctor or referred to external hospital, if he does not join his duty in the next scheduled shift on 26.12.11 (by end of shift) this is to be treated as a LOST TIME injury. Please note if the next day was a non-working day and Mr. X, in the opinion of the

act)	medical professional would not have been able to undertake his normal duties then even in this case, it is to be considered as a LOST TIME injury. If the victim is not able to report to his duty within 48 hours or more is referred as recordable lost time injury. It needs intimation to the Inspectorate of factories in Form 17.
Occupational Illness	An Occupational Illness is any abnormal condition or disorder, other than one resulting from an occupational injury, caused by exposure to environmental factors associated with employment. It includes acute and chronic illnesses or diseases that may be caused by inhalation, absorption, ingestion or direct contact. e.g. work related upper limb disorders and stress
Environmental Incident	An unplanned event in which air, water, or ground was impacted. This would include such events as leaks or spills of more than one gallon or pound of hazardous material outside of secondary containment and un-permitted discharges. It would also include events in which wastes were improperly disposed or any other unplanned environmental event requiring notification of regulatory authorities
Third party Transportation Incident	An unplanned incident involving road or third party travel such as rental cars, company leased vehicles, or movement of our goods to work sites or customers.
Product stewardship Incident	Any incident causing HSE concerns to the end users (Customers) because of our products is categorized as Product stewardship incident needs to be reported to HSE for detailed RCA, By the receiver of this type of complaint, normally customer support team.
Security Incident	Incident related to offence to person (assault, wounding, verbal abuse etc.,) or properties (theft, vehicle tampering, Property damage etc.,)

### **30.2 HSE INCIDENTS REPORTING PROTOCOL**

**Why do we need to report and investigate accidents, occupational illnesses, near misses, and unsafe acts?** To establish the immediate and basic causes and to identify actions necessary to prevent a similar occurrence & to comply with statutory & HSE policy.

**How do we report an incident?** The injured person or witness should report an incident straight away, from the location where it occurred. All Near miss, First Aid, Recordable incidents should be reported to your line manager & HSE, who will record it and look for the root cause through investigation and to prevent such incidents in future as a proactive manner.

**Note: If a particular person is not contactable it may be necessary to by-pass the hierarchy.**

**All incidents should be recorded in SAP-EHS module**

Type of Incident	Who informs Whom , How & When				Comments
	Responsibility	Inform	When	How	
Unsafe Act/ Condition	Individual	HOF, HSE	Within 24 hrs.	Safety observation	Employees are encouraged to proactively report such cases through SAP-EHS application
Near Miss	Individual	HOF, Head HSE →LT	Within 12 hrs.	Verbal/SMS /e-mail	High potential (HiPo) Near miss Incidents needs root cause analysis by HSE & Concerned team for corrective and preventive actions The report also needs circulation with HOF, LT and other concerned
First Aid/Medical Aid Cases	Victim or witnessing individual	HOF, Head HSE→LT	Within 4hrs	Verbal/SMS /e-mail	Requires Root Cause Analysis by HSE & Concerned team and the report should be circulated to HOF, LT & Other concerned
Lost time / Reportable cases	Individual→ HSE → LT	HOF→ Head	Immediate	Verbal/SMS /e-mail	FIR should be circulated to HOF/LT within 24 Hrs. & Needs Root Cause Analysis and the report to be circulated to HOF, LT & to be reported to Tata
Fatal Cases	HOF→ Head HSE → LT		Immediate	Verbal/SMS /e-mail	FIR should be circulated to HOF/LT and TATA group and the concerned statutory peoples within 24 hours. Needs Root cause analysis to be done and the report should be shared to LT & Tata Group.
Dangerous Occurrences	Individual→ Security→	Fire station Fire Station	Immediate	Verbal/SMS /e-mail	Immediate FIR should be circulated to HOF/LT and TATA group and the

such as., Fire, Explosives, Building collapse, etc., ( As per the factories rules)	IND or HOF → Head HSE → LT			concerned statutory peoples within 24 hours. Needs Root cause analysis to be done and the report should be shared to LT & Tata Group. Also notification to statutory bodies to be done in 24 Hrs.
--	----------------------------	--	--	---

### **30.3 HSE INCIDENTS INVESTIGATIONS**

**When do we need to investigate an incident?** Following an incident an investigation should be carried out for all serious or major incidents (injury or damage) and any minor incident or near-miss with a high potential of being a major one. This includes all fatalities, lost time cases, medical treatment cases and first aid injuries or illnesses. Less serious incidents should be investigated with a degree of rigor appropriate to the potential for loss or injury.

**What is the purpose of the investigation?** It is very unusual for an incident to have one single cause. Normally incidents result from a chain or combination of actions or errors, some going quite far back in time. This is why it is essential to have a systematic and thorough investigation, following a consistent methodology, so that the chain of causes can be tracked right back to its origins.

**Who investigates?** For Near miss, first aid, Medical aid HSE & Head of the department will decide the team members for doing the Root cause analysis. Specialist advice from outside the company may be required depending on the incident.

**How do we investigate?**

- 1) Establish investigation team or individual
- 2) Gather evidence and information from the scene and from the injured person and any witnesses
- 3) Establish a chain of related and unrelated events
- 4) Identify the critical factors. i.e. these are actions or events that had they not have happened the incident would not have occurred
- 5) Establish root causes (Immediate causes & Systemic causes)
- 6) Identify actions to avoid repeat and lessons for sharing

**All the Investigations should propose the recommendations to prevent such incidents by identifying the immediate cause and the systemic causes. Respective Head of the department is responsible for taking the actions to close the recommendations given in the Investigation.**

## 31. Office Safety Procedures

### 31.PROCEDURES:

**31.1. Selection of office premises:** Office buildings which are in shared facilities or commercial premises shall be selected subject to fulfilling the following minimum requirements.

**31.1.1.** The building shall have a valid No Objection Certificate from Fire department duly kept renewed or as per the local regulations.

**31.1.2.** The lifts shall have the lift license from electrical/lift inspectorate or as per local regulations

**31.1.3.** All relevant HSE clearances required as per local regulations shall be in place and valid.

**31.1.4.** Earthquake prone Area-Ensure that the buildings are designed as per the Earthquake zone of the area.

**31.1.5.** Proximity to Hazardous site- An assessment of risks to the building due to nearby location with high hazards e.g. Fuel refilling stations, ware houses, motor vehicle garages, electrical substations, Chemical/fuel bulk storage tanks, shall be done.

**31.1.6. Ergonomics and Work Environment:** Ergonomics is the science of designing workplaces, equipment and tasks to match people’s capabilities. Inadequately controlled ergonomic risks arising from activities such as manual handling and keyboard work may cause work-related injuries and illnesses and lost work time. Other aspects of the work environment, such as lighting, temperature and indoor air quality, can also affect health, safety and productivity. The proper design of tasks, equipment and the workplace environment, in conjunction with safe work practices, minimizes risks to associates and promotes increased efficiency and productivity. This procedure is in line with national and international requirements and set the minimum expectations; however locations outside India shall adhere with the requirements specific to the local legal regulations.

### 31.1.7. General Workstation Arrangements

**31.1.7.1.** Workstation layout shall be planned such that clear or easy pathway/ walkway are provided to enable ease of movement of associates towards the exit, access to fire extinguisher etc.

**31.1.7.2.** Wrist/palm supports that are fairly soft and rounded to minimize pressure on the wrist should be provided

**31.1.7.3.** Desks, chairs, and other office furniture should not be placed directly under air conditioning vents unless the vents are designed to redirect the air flow away from these areas

31.1.7.4. Cable leads from computers, telephones and other work equipment should be recessed or covered so as to avoid creating a tripping hazard

31.1.7.5. Ensure no hanging wire or wire on the ground to avoid tripping hazard or electrical short circuit.

### **31.1.8. Selection of Chair for office work**

31.1.8.1. Chairs should have a strong, five-legged base

31.1.8.2. Chairs should have casters (wheels) that are appropriate for the type of flooring at the workstation

31.1.8.3. The chair should be height adjustable so that it can be appropriately placed to fit the lower back

31.1.8.4. Backrest should have an adjustment that allows the user to recline at least 15 degrees from the vertical. The backrest should lock in place or be tension adjustable to provide adequate resistance to lower back movement

31.1.8.5. Backrest should be able to move forward/ backward, which helps the shorter users to sit with their backs against the backrest without the front edge of the seat pan contacting the knees and taller users will be able to sit with their backs against the backrest while still having their buttocks and thighs fully supported

31.1.8.6. A chair with a seat pan that is adjustable and large enough to provide support in a variety of seated postures should be provided with Height adjustment, especially when shared by a number of users. Padded and rounded seat pan, with a "waterfall" edge enough width to accommodate the majority of hip sizes. Chairs with oversized seat pans should be provided for larger users.

31.1.8.7. Seat pan "depth" adjustment to adequately support taller users while allowing shorter users to sit with their back fully supported.

31.1.8.8. Armrest should be position adjustable, so that they support the lower arm and allow the upper arm to remain close to the torso.

31.1.8.9. Armrest should be wide enough to allow easy entrance.

31.1.8.10. Armrests should be made of a soft material and have rounded edges.

### **31.1.9. Lighting /Illumination**

31.1.9.1. Illumination level of 300-400 lux is recommended for workstation and shall be ensured during planning of layout of the workstation. Local regulations/requirements may be ascertained from the local building codes or other standards. Appropriate illumination levels for other areas like passages, common areas, parking areas may be ascertained.

31.1.9.2. Indirect or shielded lighting wherever possible should be used and intense or uneven lighting which come in the field of vision should be avoided.



31.1.9.3. Ensure that lamps have glare shields or shades to direct light away from the line of sight.

31.1.9.4. Glare and reflections on the screen should be eliminated by providing appropriate arrangements and the layout of the workstation shall be planned accordingly.

31.1.9.5. Glare filters should be provided that attach directly to the surface of the monitor to reduce glare from the display unit if any.

31.1.9.6. Periodic assessment of illumination levels shall be conducted and recorded to ensure that proper illumination is being maintained.

### **31.1.10. Work Temperatures and Humidity**

31.1.10.1. A comfortable temperature range for sedentary work should be between 24 +/- 1° C or as per local regulations. Procedure should exist to periodically monitor and record temperature and humidity for larger offices (more than 50 occupancy).

31.1.10.2. General suggestions for improving thermal comfort but not limited to include:

- a. Regulating air conditioning for temperature and humidity
- b. Avoiding locating workstations directly in front or below air conditioning outlet
- c. Controlling direct sunlight
- d. Minimizing draughts and thermal differences

Proper ventilation should be maintained to ensure that there is adequate supply of fresh air as per NBC/ ASHRAE or any other equivalent standard.

### **31.1.11. Indoor Air Quality**

31.1.11.1. To prevent harmful accumulation of airborne contaminants and CO<sub>2</sub> (by-product of human respiration) within work areas, an adequate supply of fresh air should be provided (for example 55L /min for each person) and circulated to prevent the formation of "dead areas". Climate control systems should be designed and operated to specifications that will achieve optimal make-up of fresh air. This is particularly important where there is seasonal variability in outdoor temperatures.

31.1.11.2. For new occupancies with Centralized HVAC units and Air Handling Units (AHU) shall be installed for large offices, provision of online CO<sub>2</sub> monitors in the return air flow path or the AHU which are linked to the fresh air intakes to allow automatic regulation of fresh air intake based on the permissible CO<sub>2</sub> limits shall be considered. Where split / window / cassette type ACs are provided, provisions for fresh air circulation may be ensured.

31.1.11.3. ASHRAE Standard 62.1 for Ventilation for Acceptable Indoor quality can be used as a reference.

31.1.11.4. Procedures should be in place to monitor and record Indoor air Quality regularly.

31.1.11.5. Assessments of indoor air quality and thermal comfort should include as appropriate:

- a. Measurements of Volatile Organic Compounds (VOC) and carbon dioxide levels and other indoor air-quality parameters;
- b. Measurements of temperature, humidity and air changes;
- c. Discussions with associates and management regarding specific concerns and complaints using a structured format to ensure consistency in obtaining data;
- d. Walk-through evaluations of the facility, focusing on issues such as complaints, strong odours and surface contamination;
- e. Review of the work activities undertaken.

31.1.11.6. Keeping in view of internal air quality requirements, prevention of effects for passive smoking for nonsmokers and Fire prevention, procedures shall be in place to prohibit smoking inside office areas. A smoking zone should be provided as per the specifications given in Prohibition of Smoking Rules in India or its equivalent as existing in other geographies.

31.1.11.7. Where local requirements exist, procedure for microbiological control in cooling water used for air conditioning shall be documented.

**31.1.12. Slip, Trip and fall hazards:** Trips in office occur when our feet encounter an object like draws, cables, cartons etc. Slips occur when feet lose the frictional contact with floor due to presence of water, lubricating materials like oil or grease etc. Slips and trips can lead to falls which are a major cause of office injuries.

31.1.12.1. A robust system to report and rectify any slip, trip and fall hazards shall be prepared.

31.1.12.2. Provision to assess trip and fall risk while layout of furniture and equipment are laid out in an office shall be done.

31.1.12.3. Equipment and furniture layout shall be done in such a way as to minimized trip and fall hazards.

31.1.12.4. Floor ceramic tiles or other flooring material shall be slip resistant.

31.1.12.5. All sudden changes in flooring shall be avoided and where they exist be conspicuously marked.

31.1.12.6. Handrails shall be provided on both sides of stairs.

31.1.12.7. Awareness to employees to use handrails and avoiding use of mobiles while on stairs shall be provided.

31.1.12.8. "Clean as you go" programs should be in place to promptly attend to trip hazards and any spills, especially in possible wet areas like washrooms, pantry, near drinking water points, wash basins entrances etc.

31.1.12.9. Caution boards shall be placed to warn pedestrians of floor wet cleaning activity.

31.1.12.10. Periodic Safety inspections shall be carried out to identify slip, trip and fall hazards and follow up to rectify the identified hazards.

**31.1.13. Electrical Safety**

31.1.13.1. Tata Power Solar Electrical Safety procedure shall be followed for office premises.

31.1.13.2. Smoke detection and alarm system shall be provided for all offices. These should be integrated with the building’s fire detection and alarm system wherever feasible (in case of multi-occupancy buildings)

31.1.13.3. All electrical fittings shall be routed through Earth Leakage circuit breakers with 30 mA trip current or other residual current devices to prevent against electrocution.

31.1.13.4. Working on Live electrical conductor or any energy source is not permitted in office.

31.1.13.5. All electrical equipment shall be checked by competent electrician before connecting to office electrical circuit. This also applies to portable electrical equipment like pedestal fans, room heaters, etc. Periodic inspection and certification of fitness to be done

31.1.13.6. Extension cords should not be encouraged for connections which are not for short term (Maximum two Week).

31.1.13.7. All extension cords used shall be of fused type.

31.1.13.8. Electrical connections shall not lead to trip and fall hazards and adequate control measures shall be in place.

31.1.13.9. Electrically insulating mat confirming to the local regulations shall be placed in front of all electrical panels.

31.1.13.10. All Electrical maintenance activities shall be done subjected to Work permit procedures and Lock- Out /Tag- Out (LOTO) for energy Isolation procedures as mentioned in Tata Power Solar Safety Management System (TPSMS).

31.1.13.11. Electrical panel rooms shall not be used for storage.

31.1.13.12. All UPS battery rooms shall be designed to have proper ventilation to avoid buildup of hydrogen gas evolved during charging of batteries.

31.1.13.13. Smoke detectors shall be provided in electrical panel rooms and shall be connected to the fire alarm system for the office space/building.

**31.1.14. Business Continuity & Disaster Management Plan (BCDMP):** TATA POWER SOLAR has a well-defined Disaster Management Plan to meet with all types of Crisis / Emergency situations. Each division has certified DMP in line with NDMA guidelines and the plan addresses all aspects of disaster management including duties & responsibilities of key personnel, communication systems, medical facilities, emergency control centers, fire-fighting, rescue and evacuation etc. Company

facilities and critical assets have been designed to include fire detection and protection systems as per TAC / CEA / NFPA guidelines.

31.1.14.1. All office premises shall have BCDMP for foreseeable emergencies, These include but not limited to Fire, Medical Emergency, Natural calamities (like flood, cyclones, earthquakes), industrial disasters (off site chemical emergencies, gas leak etc), industrial incidents (like electric shock, LPG leak etc). Procedures shall include but not limited to following –

31.1.14.2. The organizational layout for managing the response with Names, Contact numbers and responsibilities of key personnel like emergency controller, site controller, etc.

31.1.14.3. Evacuation routes, emergency exits shall be prominently displayed on a layout map printed on a self-illuminating board (auto glow type) at each floor/section/enclosure to facilitate emergency evacuation

31.1.14.4. Provision for emergency lighting shall be provided in case of blackout during power failure during emergency. This includes work areas, wash rooms and all exit routes and staircases

31.1.14.5. Steps to be taken in case of any identified emergency including communication hierarchy and escalation matrix depending on severity of the incident.

31.1.14.6. Periodicity of regular emergency response drills for each of these scenarios including those involving external agencies together with necessary documentation to record response times, deviation from expected responses, observer's remarks etc.

31.1.14.7. Feedback mechanism on effectiveness of emergency response infrastructure identified (e.g. hardware, evacuation sequence, administrative controls, controls for people with special needs (Pregnant ladies, Persons with disability), time taken for evacuation) and effective closure of action items identified for resolving such feedback.

31.1.14.8. Office buildings situated in high rise buildings, fire emergency evacuation mock drill is advised once in every six months as per National Building Code 2005, Part IV Fire and Life Safety for India Geography and as per other local requirements in countries outside India.

**31.1.15. Floor Safety Wardens & First Aiders :** Each office shall have –

31.1.15.1. At least one person (for every 100 office occupants) trained in Basic First aid shall be available at all offices for emergency response. The number may increase based on the occupants, preferably one per 50 persons on each floor.

31.1.15.2. First aiders should also attend refresher training within 3 years of obtaining their initial qualification.

31.1.15.3. Each office location should have Floor Safety wardens identified - floor wise or as per office area & occupants.

31.1.15.4. Floor Safety Wardens names with their contact numbers & their availability shall be displayed prominently at respective floors / locations.

31.1.15.5. First aiders list along with their contact numbers (and photographs if possible- for easy identification and motivation) shall be displayed at conspicuous locations.

**31.1.16. First Aid Boxes**

- a. First aid boxes should be provided at each office floor.
- b. The first aid box shall be easily accessible to all occupants, preferably at similar location at each floor.
- c. A standard list of contents of the first aid box shall be kept in the box itself and a monthly verification of first aid box contents shall be done, including any date expired or damaged contents.
- d. Contents of first aid box should be in line with the requirements stated in latest revision of IS 13115:1991 for India geography or BS 8599-1 where no local regulations exist. Medicines shall not be a part of First aid box.

**31.1.17. Housekeeping, Chemicals storage and handling:** Chemicals in minor quantities are stored and used at offices for various purposes like pesticides, room fresheners in aerosol form, cleaning chemicals etc. These are harmful with respect to Health, Fire or reaction with other chemicals.

31.1.17.1. Eco-friendly / non-toxic cleaning and housekeeping chemicals should be procured to the extent possible.

31.1.17.2. Any material stored in office premises shall be with appropriate label from the manufacturer.

31.1.17.3. Material Safety Data Sheet (MSDS) from the manufacturer shall be obtained and shall be made available in chemical storage area.

31.1.17.4. All users shall be given adequate training on handling, storage, disposal of waste and emergency care in case of a contact.

31.1.17.5. A procedure for chemical inventory management shall be documented to ensure.

- a. Chemicals are not ordered beyond a reasonable quantity for short term use.
- b. Chemicals issued to trained users after due authorization.
- c. Monthly check on quantity in inventory is taken.
- d. Personal Protective Equipments are available.
- e. First aid provisions are available.
- f. Disposal of waste happens in approved manner only.

31.1.17.6. Aerosol cans used for room fresheners contain flammable expellant shall not be burned with regular waste even when empty. Such cans shall not be stored near ignition sources.

**31.1.18. Manual Material Handling:** Handling and storing materials involves operations such as lifting and stacking drums, pushing trolleys carrying materials, carrying heavy objects etc. Bending, twisting, and turning are the movements that cause back injuries. Over-exertion cases are due to lifting, pushing/pulling, and carrying.

Associates/ contractors working can also be injured by falling objects, improperly stacked materials or by equipment. Potential injuries include strains/sprains from improperly lifting loads or carrying loads that are too large or heavy, fractures/bruises caused by being struck by materials or being caught in pinch points, and cuts/bruises caused by falling materials that were improperly stored or by incorrectly cutting ties or other securing devices. Requirements of safe handling of materials are as under-

31.1.18.1. General instructions for handling material and safe posture while handling material shall be prepared for support staff and training provided.

31.1.18.2. Where ever possible lifting & carrying tools and equipments shall be provided.

31.1.18.3. Appropriate Personal Protective Equipment (PPE) shall be given while manual handling. For example Safety gloves, Safety shoes, safety goggles etc.

31.1.18.4. All the equipment used for pushing, pulling, carrying the load such as trolleys, pallets shall be inspected before every use and shall be tested according to defined frequency as per OEM recommendation..

**31.1.19. Provision for People with Differently abled persons (Disabilities):** A disability refers to a physical & sensory limitation that interferes with a person's ability to move, see, hear or learn. Where Large Offices buildings are acquired or built, and are intended to be used by People with differently abled (Disabilities), The following are the areas requiring attention.

- a. Obstructions
- b. Signage's
- c. Pathways
- d. Curb ramps
- e. Pedestrian crossings
- f. Parking
- g. Emergency communication systems
- h. Washrooms.

**31.1.19.1.** The infrastructure shall be in line with the NBC guidelines for India Geography and relevant local regulations for International Locations.



### 31.1.20. Exit and Safety Signage

31.1.20.1. **Exit Signs:** Signs shall be posted to indicate the ways to emergency exits, especially at corridors, exits and wherever there is a change in direction. Sizes and type of signage shall be as per the local requirement. Floor signs can be glow back (photo luminescent) type or back lit type. For India Geography, National Building Code Part IV Fire and Life Safety specifies back lit signs for emergency exit routes with backup power source.

#### 31.1.20.2. Safety Signs

- i. Prohibition signs – White/black letters or graphic with Red back ground
- ii. Mandatory Signs- Black letters/graphics with Blue back ground
- iii. Warning/caution signs – Black letters or graphics on Yellow back ground
- iv. Safety Signs, Emergency escape signs- White letters/graphics on Green Back ground

31.1.20.3. **Safety hazards,** Escape routes shall be marked

as per IS 9457:2005, IS 12349:1988 and electrical hazards as per IE rules 1956 for India Geography or as per applicable local regulations or signs in respective geography. BS 5499 may be referred where no specific local regulations exist.

**31.1.21. Food Safety in Canteen or at Eating places:** Each Tata Group company should have a Food Safety and Hygiene management program to ensure the following-

31.1.21.1. Prevent food degradation / contamination that can lead to transmission of food-borne diseases and food poisoning where canteen is operated. This could be based on Food safety standards applicable under local regulations, Hazard Analysis and Critical Control Points (HACCP) or ISO 22000 (Food Safety management System) as deemed fit for purpose.

31.1.21.2. Ensure safety of. Employees, associates, canteen staff and property by:

- a. Provision of adequate safety and hygiene-related features while designing the canteen and other related facilities
- b. Adhering to the applicable local regulations while setting up or operating canteens or vendor counters for food dispensing. (E.g. Food Safety and Standards Regulations in India) as a minimum.
- c. Following all safety related operating procedures and practices, including maintenance, inspection and testing of all safety-related equipment and systems (LPG manifolds, Boilers etc)
- d. Maintaining a process for First in First Out for maintaining stock of food materials
- e. Proper arrangement for storage of food stuff in specified temperatures.
- f. Food preparation, Serving and dining areas are maintained to ensure proper hygiene.



- g. Medical examination of personnel involved in food handling at least once in six months.
- h. Periodic testing of food samples as per local regulations as applicable for cooked and ready to eat food or on a monthly basis.

31.1.21.3. The following parameters shall be analyzed to check whether the food meets the desired standards for human consumption.

- a. Aerobic Colony Count
- b. Escherichia coli (E. coli)
- c. Staphylococcus aureus
- d. Clostridium perfringens
- e. Bacillus cereus
- f. Salmonella
- g. Ensure training and awareness sessions are conducted for the canteen staff on food hygiene, personal hygiene and safety practices to be adopted
- h. A prequalification and selection of canteen vendor based on hygiene.
- i. Periodic Inspection of food preparation, serving and dining areas.

31.1.21.4. Where a central kitchen is used to prepare food and carry to a serving area in office premises

- a. Inspection of vendor kitchen
- b. Ensuring hygienic condition of vessels and vehicles to transfer food from central kitchen.
- c. Process to avoid contamination while transfer.
- d. Provision to maintain proper temperature till the food is served.
- e. Ensure segregation of waste and appropriate handling and disposal of wet and dry wastes.
- f. Audit process to ensure that the process is implemented and continually improved.
- g. Ensuring quality of drinking water supplied at the premises by periodic monitoring of parameters laid out in local regulations. (E.g. monthly monitoring of microbiological parameters, annual testing as per IS-10500 in India or as applicable in other geographies).
- h. Package drinking shall be as per applicable local regulations and standards (E.g. IS 14543 for packaged drinking water in India)

**31.1.22. SAFETY AUDITS, WALK THROUGH & INSPECTIONS PROTOCOL:** Office safety audits shall be conducted for ensuring that systems are in place to identify, provide, and maintain the basic requirements for office safety as per existing safety organization structure.

31.1.22.1. In order to enhance the overall standard of safety performance in Office premises, it is necessary to conduct safety audits with Safety Assurance Checks and Safety Inspection.

i. Safety Walk Through – shall be done by Senior management along with Floor Safety Wardens / Safety Steward / Coordinator. This process will ensure the involvement / commitment of Senior Management and people participation.

ii. Office Buildings / Premises Fire & Safety Audits as per statutory requirements applicable to that locations shall be carried out.

**31.1.23. EMERGENCY SERVICES:** Emergency Services contact numbers for that particular Divisions / Locations to be displayed prominently in every Office Buildings.

**31.1.24. MEDICAL**

31.1.24.1. In case any employee is injured he /she should receive First Aid immediately and inform the supervisor.

31.1.24.2. The employee should not leave the injury unattended whether it is minor or major.

31.1.24.3. He/ she should receive first aid through any of the listed First Aiders. The First Aid box is available at Receptions/Every department.

31.1.24.4. Any medical emergency should be immediately reported to OHC/Reception

31.1.24.5. A First Aider/Doctor is to be called to attend the person immediately.

31.1.24.6. List of Floor Safety Wardens / First Aiders shall be displayed in each floor. The ES & A will arrange the transportation of the person to the hospital for further treatment if required.

**31.1.25. FIRE PROTECTION & PREVENTION:** All employees should be aware of the fire protection equipment within each facility they work or reside in, as well as know fire safety and prevention measures to ensure a safe environment. This can be accomplished through special training classes and employee development classes. This training will help ensure employee awareness as well as the following common compliance issues:

a. Maintaining the automatic operation of fire alarm & fire prevention systems.

b. Maintaining a clear unobstructed exit passageway.

c. Maintaining common areas such as corridors, halls free of obstruction and combustible materials, including the limitation of paperwork, posters, and similar combustible products on walls and doors.

d. Maintaining a safe egress system by ensuring the exit system is maintained free of obstruction from equipment, machines etc.

e. How to report a fire and how to evacuate a building as well as extinguish a fire.

### **31.1.26. ROLES & RESPONSIBILITIES**

31.1.26.1. **Senior leadership:** Establish and encourage a safety culture through actions and deeds. Actively support all issues for improvement in Safety and assume responsibility.

31.1.26.2. **Safety & Security Officer:** In case of emergency Security / Safety Officer shall:

- a. Be the focal point in handling the information. Act according with the procedures given in Disaster Management Plan (DMP).
- b. Organize - when, how & what action to be taken in accordance with standard procedures and instructions
- c. Immediately contact ES & A and give brief report with relevant and critical details
- d. Coordinate/ team up with personnel to extinguish the fire.
- e. Have the access to the keys of restricted entry areas.
- f. Disable the automatic access control system.

### **31.1.26.3. Floor Safety Wardens Responsibilities:**

- a. Floor warden shall coordinate and monitor office safety inspections in his/her floor.
- b. He/she must be familiar with the fire safety plan of building.
- c. During fire/emergency, he/she shall ensure that emergency instructions are followed by floor occupants and nobody is left in the floor.
- d. In case any person is missing or trapped in the floor, he/she shall inform fire/operation control room for rescue.
- e. He/she shall make a list of physically handicapped/disabled persons working on his/her floor and pay special attention to them during evacuation.
- f. Ensure safe and orderly evacuation of occupants of area of building.
- g. Take head count of occupants after assembling at safe assembly area.
- h. Get trained in first-aid, basic fire fighting and rescue techniques.

### **31.1.26.4. Floor Safety Wardens Role:**

- a. He shall be member of Office Safety committees established under the chairmanship of Office custodians.
- b. He shall conduct regular safety inspections at his floor & do the necessary follow up to close out of any safety violations.
- c. Act decisively during an emergency.
- d. Put on fluorescent jacket and guide/issue instructions.
- e. Lead floor occupants out of the building to Safe Assembly Area / Shelter.
- f. Knock on bathrooms on the way out and announce the emergency. Close doors on the way out.

- g. Note any pertinent observations on the way out of the building (smoke, people not leaving, etc.) and report to the Safety/Security Officer.
- h. Know the emergency evacuation routes and location of exits for the building.
- i. Identify any disabled personnel and work out a plan for their evacuation.
- j. Know the location of fire extinguishers and how the alarm system works.
- k. Report problems to concerned department if exit signs or emergency lights do not work.
- l. Report problems to concerned department if Exits or Aisles are not clear of equipment, boxes or furniture.
- m. Be available to personnel on floor to explain evacuation plan and emergency procedures.
- n. Participate with other floor wardens and Office Coordinator in preparing, scheduling, and conducting evacuation exercises.
- o. Take advantage of training opportunities such as First Aid, and Fire Safety given by organization.

**31.1.26.5. Employees:**

- i. Should follow the office safety guidelines while at work so as to make the office environment free of hazards.
- ii. Be alert to unsafe conditions and report the same to immediate supervisor or in online safety portal in SANGAM or thru Suraksha Mobile app.
- iii. Do not use narcotics & alcohol in the office and do not bring any life threatening items like firearms, explosives & knives etc. to the office.
- iv. Make effort to ensure the safety of his/ her colleagues.

**31.1.26.6. Visitors:** TATA POWER SOLAR has visitor management system in place at all locations. Visitors shall obtain necessary permission to enter & follow the instructions/guidelines. Visitor badge if given should be prominently displayed all the time. Employee shall accompany their visitor inside the office. At no point of time, any visitor is left unattended within the office premises. The employee with visitor shall guide him in all events of an emergency.

**31.1.27. Welfare Facilities:** Welfare facilities include the provision of adequate toilet and washing facilities. The facilities should be in sufficient numbers and be clean, well maintained and have adequate ventilation. Hot and cold water, soap and hand drying facilities should also be in place. The provision of suitable drinking water is also a statutory requirement.

**31.1.28. INCIDENT / ACCIDENT REPORTING:**

31.1.28.1. All incident reporting shall be done as per Tata Power Solar Incident reporting & Investigation procedure.

31.1.28.2. The injured person should report the incident immediately: To his supervisor / to the Department Head (in the absence of supervisor) or To the Safety Officer.

31.1.28.3. He is expected to co-operate with Medical Officer / First Aid specialist in for necessary first aid / treatment.

31.1.28.4. The advice of Medical Officer / First Aid Specialist is binding on all concerned personnel.

31.1.28.5. After notifying the Medical Officer / First Aid Specialist, the Supervisor must ensure the shifting of the injured to Occupational Health Centre / Dispensary / external hospital either using the ambulance / vehicle or with the help of co-workers of the injured employee. He should report the incident to the management immediately.

**31.1.29.RECORDS :**

**31.1.29.1.** Monthly Office Safety Walk Through Checklist (TPSMS/GSP/OFS/007/FORM/001) – Retention period one year.

**31.1.30. TRAINING & COMMUNICATION**

**31.1.30.1.** Fire Fighting: All first aiders, other interested/ potential employees and security staff shall get a briefing/awareness on how to use the firefighting equipment's.

**31.1.30.2.** First Aid: First Aid training shall be provided to the identified employees and shall be designated as First Aiders.

**31.1.30.3..** Initial Communication to be done through Corporate Communication, Email and subsequently shall be made available at safety portal at Sangam.

**31.1.31. VERIFICATION**

**31.1.30.1.** Verification of implementation shall be done during Office Safety audit, office inspections visit.

**31.1.31. EXEMPTION:** Any Exception to this procedure shall only be done as per Document Control .Procedure (TPSMS/GSP/DC/014/).

**31.1.32. REFERENCES**

- National Building Code: 2005
- National Building Code 2005, Part IV Fire and Life Safety
- IS 9457:2005,
- IS 12349:1988
- Electrical hazards as per IE rules 1956
- IS 13115:1991

- IS 14543 for packaged drinking water in India
- IS-10500
- Tata Power Solar Safety Signs Guidelines

**31.1.33. REVIEW:** Review of this procedure shall be done as and when but not later than once in every three (03) years. Typical Factors like Changes in legislation, Review of Incident Reports, Inspection & Audit findings, Feedback from users, Recommendations in Incident investigation reports may be inputs for the review and revision of the procedure.